

Year of Manufacture: 20 _____

Original Instructions

VASTEX

SCREEN PRINTING EQUIPMENT

E-200 LED Exposing Unit

Assembly and Operation Instructions



E200-2128



E200-2331

Vastex International, Inc.
 7 Emery St
 Bethlehem, Pa. 18015 USA
 Phone# 610 625-2702
 Fax# 610 625-2775
 Web Site www.vastex.com

Contents

	Pg. #
Introduction, Machine Specifications	2
Safety Information	3
Assembly Instructions	4
Operating Instructions	5
Maintenance	6
Troubleshooting	7-8

Authorized Representative in Europe:
 Certification Experts BV
 Nieuwstad 100 1381 CE Weesp,
 The Netherlands
 Tel : + 31 (0) 294 – 48 33 55
 Fax : + 31 (0) 294 – 41 46 87

Electrical Drawing #: _____ Revision: _____

Serial Number: VTX Date: ____/____/____

(Please log your machine's serial number and date of purchase for future reference.)

Vastex E-mail assistance

Purchasing & Product Info:
sales@vastex.com

Tech Support:
techsupport@vastex.com



Warranty

A copy of the warranty is also available at:
<https://www.vastex.com/Library.php>

Introduction

Vastex Exposing Units (LED Exposure Systems)

Thank you for purchasing your printing equipment from Vastex International Inc.

Vastex has been designing and building printing equipment since 1960. We have knowledge and experience, and are proud to supply the printing industry with quality equipment at an affordable price. You can be confident your purchase will give you years of trouble free service.

Machine Specifications & Part Numbers

	E200-2128	E200-2331
Overall Size (lid closed) Depth x Width x Height	32.75" x 37.75" x 14" (83 x 88 x 36 cm)	36.5" x 41.75" x 14" (93 x 106 x 36 cm)
Weight	151 lbs. (68.5kg)	174 lbs. (78.9kg)
Screen Capacity	21" x 28"	23" x 31"
Power Requirements	120v: 60Hz @ 3.0 Amps 240v: 50/60Hz @ 1.5 Amps	120v: 60Hz @ 3.5 Amps 240v: 50/60Hz @ 2 Amps
Vacuum Pump	1/16 HP Diaphragm Pump (120V P/N: 04-02-040) (240V P/N: 04-02-041)	1/16 HP Diaphragm Pump (120V P/N: 04-02-040) (240V P/N: 04-02-041)
Vacuum & Exposure Timer	Analog P/N 04-01-085	Analog P/N 04-01-085
Glass Reorder Numbers	P/N: 04-08-060	P/N: 04-08-048
LED Light Bar	LED Light Bars P/N: 04-08-056	LED Light Bars P/N: 04-08-054
LED Power Supply	P/N: 04-08-057	P/N: 04-08-055
Vacuum Blanket	P/N: EUB-2128	P/N: EUB-2331
Lid Seal	P/N: 04-08-039	P/N: 04-08-039
Floor Model/Tabletop	Table Top, optional stand available	Table Top, optional stand available
Warranty	3 Years; Manufacturer Defects	3 Years; Manufacturer Defects

Safety

Intended Use:

This equipment is intended for the purpose of exposing screens and films with UV light in conjunction with UV sensitive emulsions.

Safety:

- The operator should read and understand this manual before operating this equipment. Store manual and safety information near equipment for easy access to operators.
- Never leave equipment unattended while in operation.
- Children and pets must be kept clear of the work area.
- Do not store any objects on top of the exposing unit.
- Unplug power cord before removing glass or entering control box.
- Do not operate if any guard or cover has been removed.
- Do not operate if power cord is damaged.
- Safe Operating Temperature (Ambient): 55°F-100°F (13°C-38°C)
- Do not attempt to defeat safety interlocks.
- Noise and Vibration: This noise level produced by this equipment does not exceed 70 dB(A).

**** WARNING HANDLE GLASS WITH CARE ****

- Wear gloves when handling the glass
- Lay glass only on a flat protected surface
- Tempered glass, although strong, can shatter if the edges are subject to an impact

General Information

- Exposing Unit must be on a flat surface to eliminate stress on the glass.
- Caution! Screens must be free of sharp edges. All surfaces coming in contact with vacuum blanket should be rounded and smooth.
- UV LED Lights are used in this machine. The lights should Not Be viewed during operation without eye protection.
- Keep the lid in the raised position when not in use. It will increase the life of lifting cylinders and the rubber blanket.

Tools Required

- Philips Head Screw Driver
- 7/16", 1/2", 9/16" & 5/8" Wrenches
- **OR METRIC:** 11mm, 13mm, 15mm, 16mm

Assembly

Getting started:

Your Exposing Unit has been fully assembled and tested in our factory. Both lid lifting cylinders have been removed from their upper mounting stud and secured to the side of the cabinet. Be careful not to damage the rubber vacuum blanket when removing the Exposing Unit from its crating.

It is best to keep the lid locked closed when lifting the exposing unit. Carefully remove the unit from its crate and place it on a suitable surface. It is important that the surface be flat, an uneven surface can put stress on the glass causing it to crack.

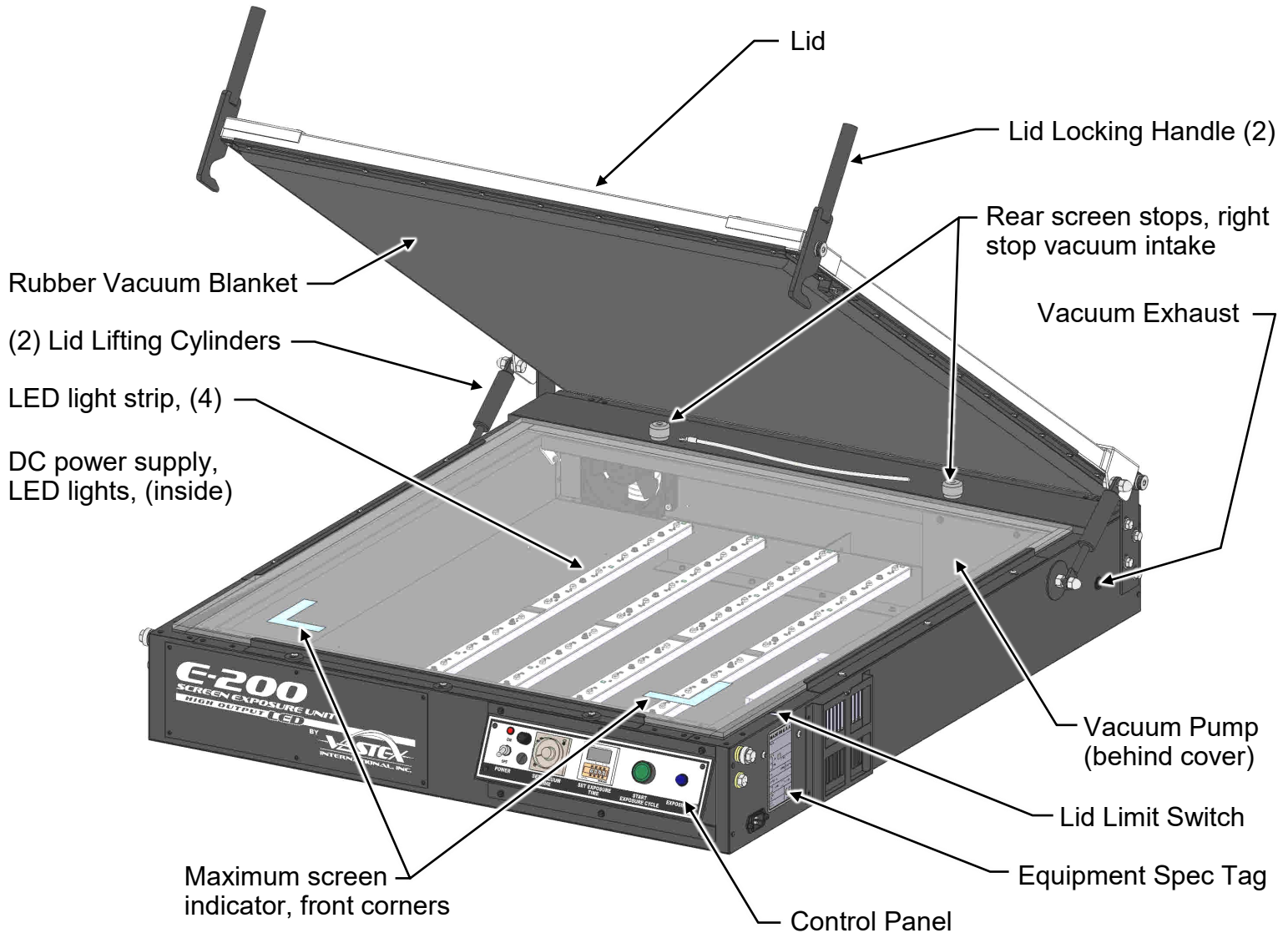

E200-2331 shown
E200-2128 components may be located elsewhere

Install Lid Lifting Cylinders

Remove the acorn nut from the upper cylinder mounting studs located on both sides of the lid. Unlock and carefully lift lid far enough to slide lifting cylinders onto studs. Replace acorn nuts onto stud. **Snug only** with a 5/8" wrench. Do not over tighten!

Operation

Overview:

Your Exposing Unit is equipped with LED Lights, vacuum timer, exposure timer, vacuum pump, and separate switches for main power and exposure cycle start. The vacuum pump draws the air out from between the blanket and glass. This flattens the coated screen and positive to the glass making for a sharper exposed image.

Sequence of Operation

- 1) Raise the exposing unit lid and wipe the glass surface clean with a lint free rag.
 - 2) Position the screen with positive attached, onto the glass and against the two back screen stops.
- Do not position any screen outside screen area indicated by the labels. Damage to vacuum blanket can result.**
- 3) Lay the small string attached to the rear of the exposing unit over the edge of the screen to assist in achieving a good vacuum in the center of the screen.
 - 4) Lower the lid and lock closed with both handles.
 - 5) Turn on the power switch.
 - 6) Set the Vacuum Time. (See Tips).
 - 7) Set Exposure Time. (See Tips).
 - 8) Start Exposure Cycle. The vacuum pump will start. After the vacuum timer has reached preset time the LED lights will start. After the exposing time has expired, the lights and vacuum pump will automatically shut off. The screen is now exposed.
 - 9) Unlock the lid to break the vacuum and remove the screen.

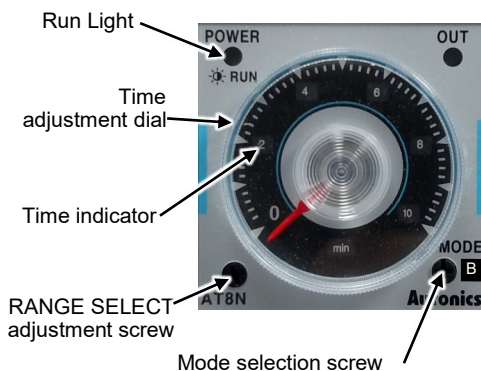

Vacuum timer is factory set to a 0-1 minute scale. The mode in the lower right corner is set to B. Typical vacuum time is just under 1 minute. For exposure tips, please see above.

Tips

Vacuum Time: (for each size screen)

Lock lid and set vacuum time to 1 minute. Start cycle and record the time it takes to flatten the blanket to a size larger than your positive. If unsure, wait until blanket is flat to within 2" (5cm) of frame. If desired, adjust the range and time scale by turning the RANGE SELECT and unit selection screw with a Philips head screw driver.

- Turning RIGHT increases the time scale
- Turning LEFT decreases the time scale

MODE MUST BE SET TO B

Exposure Time:

A full and complete exposure will be effected by several variables listed by importance.

- 1) Type and brand of emulsion
- 2) Thickness of stencil (qty. of coats or capillary film thickness)
- 3) Mesh color
- 4) Humidity

For this reason the only proper way to determine the correct time for a full and complete exposure is to use a "Exposure Calculator". Several types of calculators are available, contact your supplier to determine which is best for you.

Approximate setting for single part or "Pure Photopolymer" is: 10 – 30 seconds.

Approximate setting for "Dual Cure": 1 – 5 minutes.

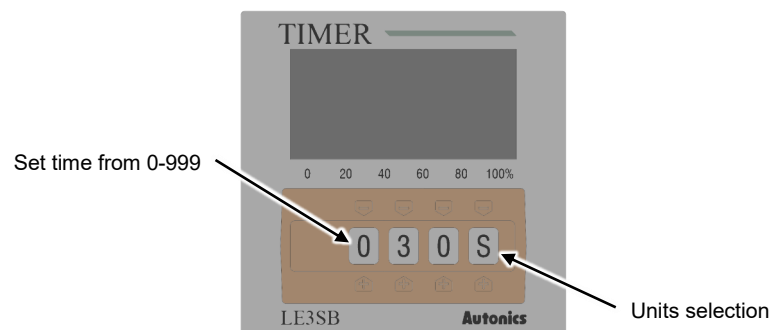

Exposure timer is set at the factory to minutes. Adjust the timer using the four buttons on the bottom. The letter on the right corresponds to the units of time being measured. A capital "S" stands for seconds, "M" for minutes.

Maintenance

Do Not allow objects to contact the LED light lens.

Wear gloves when handling the glass. Glass is tempered and although strong, can shatter if the edges are subjected to an impact.

Glass Removal / Installation

There are three glass retainers. One on each side to square the glass to the rear seal and one in the front with special cams. The cams are used to gently push the glass back against the rear seal.

- 1) Remove the cams and front retainer. Slide the glass towards the front to remove. Carefully set glass on a flat, protected surface. The cams are used to gently push the glass back against the rear seal.
- 2) It is important to keep the inside of the cabinet clean. It is a good idea to vacuum out any loose debris from inside the cabinet. Refer to the replacing a light bar if needed.

3) Reinstalling the glass.

Before installing the glass, switch the vacuum pump on and off to verify it is functioning properly. Clean both sides of the glass with glass cleaner and a lint free rag. Vacuum inside of cabinet. Position the glass seal side down, blue tape towards the front, on the front edge of the cabinet, and between the side retainers. Slide glass back until it contacts and it seated squarely against the back seal. Place the front glass retainer and the three cams against the glass front. Install the screws but only snug the screws. Using a 1/4" flat screw driver in the cam slots, rotate each cam to push the glass back. Do not over tighten the cams but apply enough pressure to make a seal. Now tighten the center screws. If the vacuum leaks, go back and tighten the cams a bit more.

- 4) Inspection of LED light bars done monthly. See page 8, step1, for instructions.



Note: The glass must be tight against the back glass seal in order to make a good vacuum. Special cams help to apply pressure. Do not over tighten.

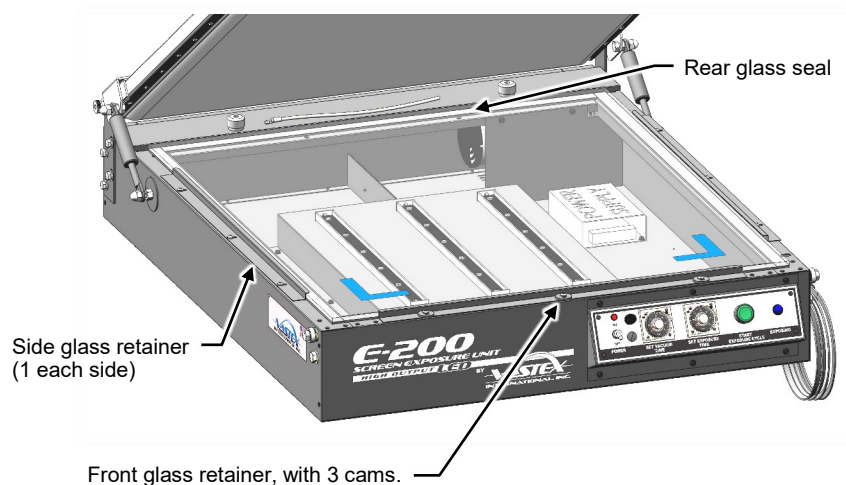

Troubleshooting

Loss of Vacuum

This can be caused by several problems. Check the following items in order listed.

- 1) Verify that vacuum pump is running.
- 2) Examine the rubber blanket for holes or cuts.
- 3) Check that the holes in the back left screen stop is not blocked. Turn on the pump and verify that there is vacuum through the left stop.
- 4) Check that the clear tube protruding through left side of cabinet wall is unobstructed. This is the vacuum pump exhaust.
- 5) Verify that the back glass seal is not damaged. If it is not try tightening the front cams just slightly. If this does not work, pull the glass away and inspect the seal, then reseal the glass squarely against the back seal and retighten the front cams.
- 6) There is a foam seal around the perimeter of the lid between the rubber blanket and lid frame. With the lid locked down, check that the lid seal and blanket is contacting the glass at all four sides. If this seal is not contacting the glass it will be necessary to adjust the lid lower.
Proceed as follows (pictures below for reference) .
 - a) Remove both Lid Lifting Cylinders from their

upper mounting stud. Carefully lower the lid.

- b) **Rear Seal Adjustment. Start with the lid down and locked.** Using a 7/16" wrench, loosen the four (4) bolts along the side of one corner, just 1/8 turn each bolt. Using a piece of wood and a hammer, tap lightly at the top corner to compress the rear seal. Measure the distance before and after, do not adjust more than 1/16 of an inch. Do this to both sides until vacuum seal is achieved.
- c) **Front Lid Adjustment.** Using a 9/16 wrench, loosen (2) bolts at each front corner about 1/8 of a turn. Using a piece of wood and a hammer, tap on the top bolt head slightly to move the bearing down. Be careful to avoid moving it too much. For reference, measure from the top of the bearing to the bottom of the lid when closed, do not adjust more than 1/16 of an inch. Retighten all fasteners.
- 7) Contact Vastex for technical support if these steps fail to resolve the problem.

Lid adjustment bolts

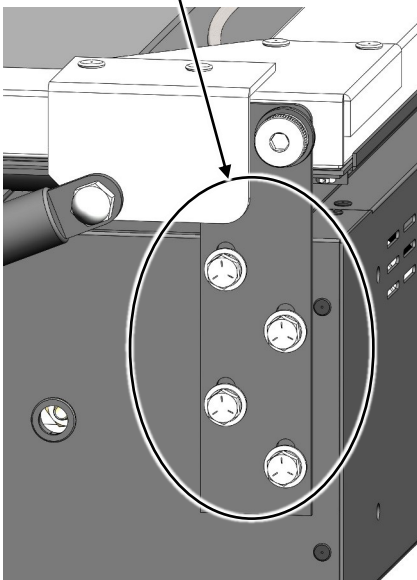

Rear Lid Adjustment

Loosen 1/8 turn for adjustment

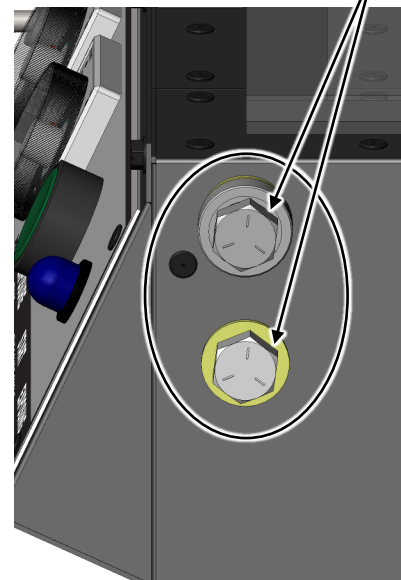

Front Lid Adjustment

Troubleshooting

Light Bar Replacement / Installation

Note: It is important to wear dark shaded and UV rated eye protection when testing LED Lights.

Do Not allow objects to contact the LED light lens.

- 1) Inspection of LED light Bars. Lift the lid and override the safety switch on the left side of the cabinet by depressing with your finger or a pencil. Turn the vacuum timer all the way down. Put your sunglasses on and hit the start, with the lid up view if ALL lights are working. If not proceed to step 2. Contact factory for replacement light bar.

It may be possible to expose screens with LED lights out, but a repair is needed to ensure optimal performance.

- 2) Remove exposing unit glass, see Maintenance section for glass removal.
- 3) Unplug main power cord, unplug light bar connector, and remove both #8 sheet metal screws holding the light bar in place. Each light bar has a power connector.
- 4) Installing the new light bar. Install the #8 sheet metal screws, plug in the light bar connector, plug in the main power cord.
- 5) Test the new light bar. See above section 1.
- 6) Replace exposing unit glass.

Note: E200-2331 light bar connectors (shown) are in the front of the unit. E200-2128 connectors are toward the rear of the unit.

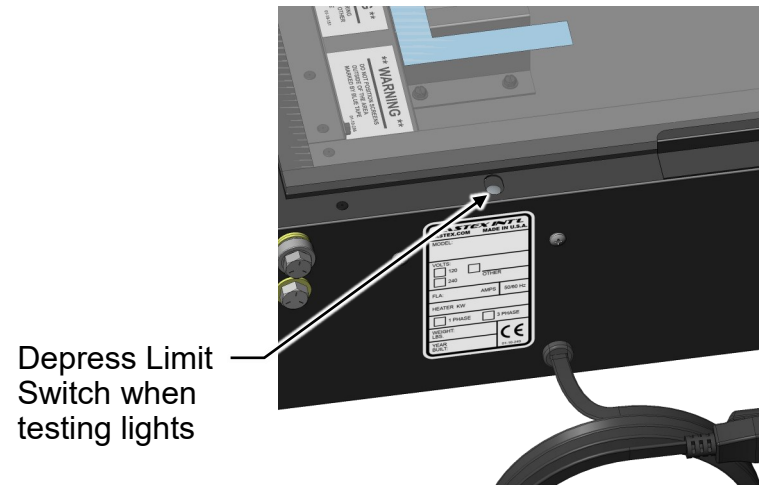

Depress Limit Switch when testing lights

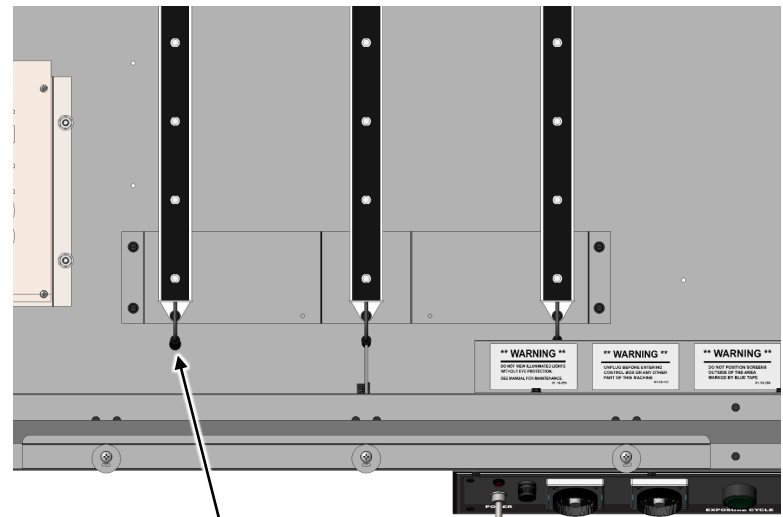

Light bar connector