

Year of Manufacture: 20_____

Doc # 01-08-042L
February 2, 2026

Original Instructions

VASTEX

SCREEN PRINTING EQUIPMENT

V-1000 Printer

Assembly and Operations Manual

Floor and Tabletop Models

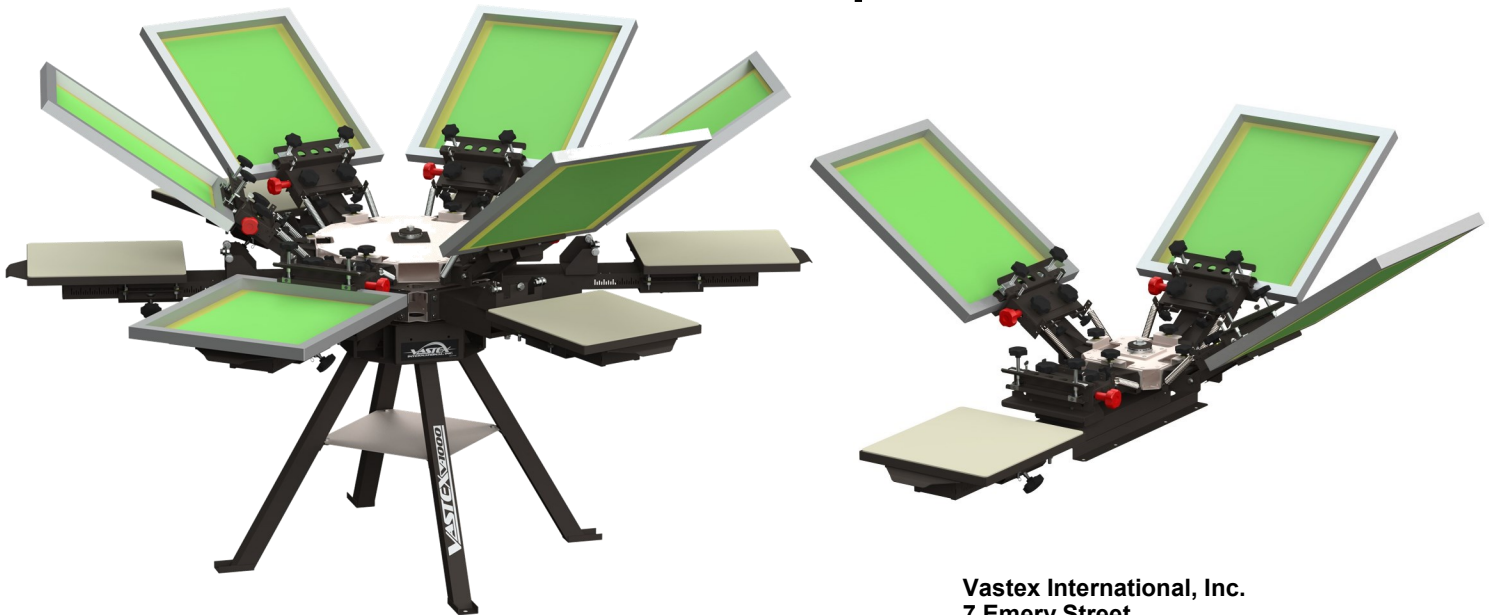

This manual contains the following documents:

- Introduction / Safety / Features Pg. 2-3
- Contents of boxes Pg. 4
- Printer Overall View Pg. 5
- Component Identification / Print Head Pg. 6
- Assembly Instructions Pg. 7-14
- Drop Down Wheel Set Installation Pg. 9
- Wheel Lock Housing Checking Level Pg. 11
- Pallet Assembly Pg. 15-16
- Pallet Leveling Pg. 17
- Print Head Leveling Pg. 18-19
- Lubrication / Maintenance Pg. 20

Vastex International, Inc.
7 Emery Street
Bethlehem, PA 18015 USA
Phone# 610 625-2702 Fax# 610 625-2775
Web Site www.vastex.com

Authorized Representative in Europe:
Certification Experts BV
Nieuwstad 100 1381 CE Weesp,
The Netherlands
Tel : + 31 (0) 294 – 48 33 55
Fax : + 31 (0) 294 – 41 46 87

Vastex E-mail assistance

Purchasing & Product Info:
sales@vastex.com

Tech Support:
techsupport@vastex.com



Warranty

A copy of the warranty is also available at:
<https://www.vastex.com/Library.php>

Serial Number: VTX_____ Date: ___/___/___

(Please log your machine's serial number and date of purchase for future reference.)

Introduction

Thank you for purchasing your printing equipment from Vastex International Inc.

Vastex has been designing and building printing equipment since 1960. We have knowledge and experience, and are proud to supply the printing industry with quality equipment at an affordable price. You can be confident your purchase will give you years of trouble free service.

Safety

Intended Use:

This equipment is intended for performing manual screen printing of fabric items, particularly garments. This equipment must not be used in a manner contrary to what is described in this manual.

Safety:

- The operator should read and understand this manual before operating this equipment. Store manual and safety information near equipment for easy access to operators.
- Keep children and pets clear of the work area.
- Do not sit or stand on printer.
- The print heads utilize heavy duty springs to hold the screen in the raised position. These springs generate a lot of force. Care must be taken when installing and removing the print head lifting springs.
- Do not operate printer without print head stop bar in place.
- Do not allow print heads to swing into their raised position unrestrained.
- Screens should be installed and removed with print heads in their raised position.
- Print heads should remain in their raised position when not in use.
- Do not set foreign objects on any part of the press.
- Noise and vibration: This noise level produced by this equipment does not exceed 70 dB(A).

Features

- Steel Pallets w/rubber top
- Floating Print heads allows multiple heads down
- Micro Registration
- 6 way head leveling
- Available up to 8 table 8 color
- Accurate multicolor registration
- Expandable from 1x1 to 8x8
- 3 year warranty on manufactures defects
- HD Head upgrade available

Tools Required

- 1/4", 7/16", 9/16" Wrench, or optional Adjustable Wrench,
- 9/16 socket, ratchet and extension, level

— Stability during use, transportation, assembly, foreseeable breakdowns, etc. —

This equipment is designed and expected to be stable during all normal conditions of use.

- When assembling your press, do not stand tall parts upright until you are ready to install them; lay them flat instead.
- It is recommended that assembly should be done by two or more people, to facilitate the alignment of parts that must be bolted together.
- If one or more legs of the press will be removed, be certain to adequately support the rest of the press.

— Safe handling, transport, and storage of the press —

Your press is designed to be inherently safe under all normal conditions. When handling or transporting your press, be aware of the weight of your unit and have an appropriate number of people to lift the weight safely: V1-44 — 256 lbs (116 kg); V1-46 — 308 lbs (140 kg) V1-66 — 400 lbs (181 kg) V1-88 — 520 lbs (235 kg)

If your press is to be moved or transported regularly, it is recommended that you purchase the optional casters.

— Placing this equipment into service —

To place your press into service —

- 1.) Review the photographs on pages 4 through 6 to familiarize yourself with the parts of your press.
- 2.) Follow the assembly instructions on pages 7 through 12.
- 3.) Make final adjustments to your press; follow instructions on pages 13 through 15.

— Operating this equipment —

To operate your press —

- 1.) Clamp your first screen into head #1.
- 2.) Repeat for additional screens, using additional heads.
- 3.) Place garment in pallet #1.
- 4.) Lower print head and squeegee ink through screen.
- 5.) Raise print head. For one-color printing, load new, blank garment and repeat steps above.
- 6.) For multi-color printing, rotate the pallet to print head #2 and repeat steps above until all colors are printed.
- 7.) If any adjustments to the print heads need to be made, refer to the instructions in this manual.
- 8.) **Flashing** should not exceed 15 seconds or 200°F (93.3°C) to protect rubber pallet tops.

— In the event of an accident or breakdown —

In the unlikely event that a part of your press breaks, or if your press does not seem to be operating normally and the instructions in this manual do not correct the issue, do not continue using your press. Contact Vastex for assistance in repairing your press.

— Safety during maintenance or while making adjustments —

- When cleaning or lubricating your press, make sure that nobody in the work area is close enough to cause any part of the press to move unexpectedly.
- Do not remove springs unless under the specific direction of Vastex customer service.
- Observe the general safety cautions on page 2 of this manual.

Contents of Boxes

Your Printer has been packaged in several pre marked boxes. The printer you ordered may consist of several combinations of the following boxes.

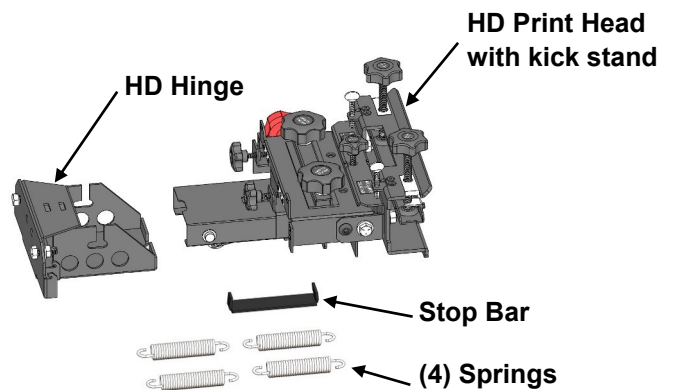
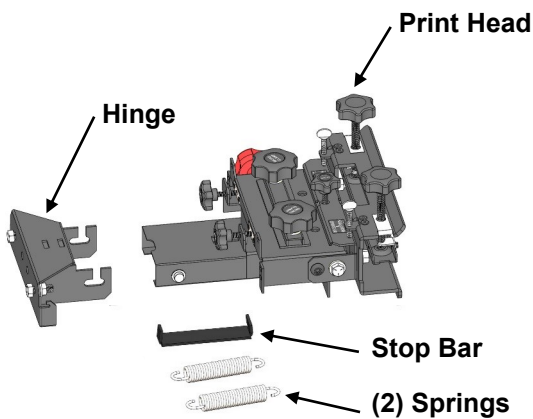
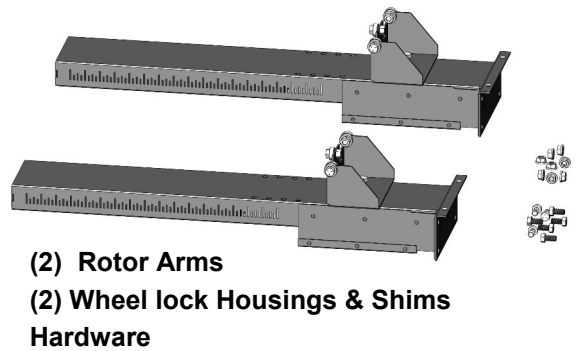
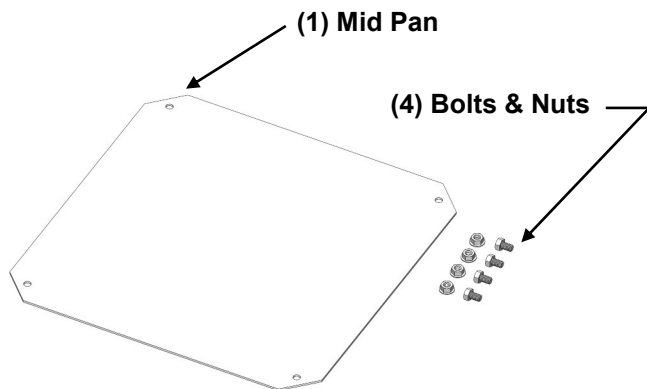
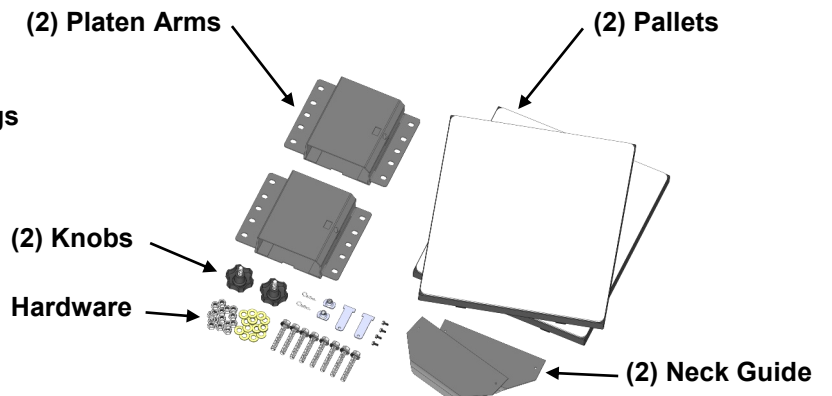
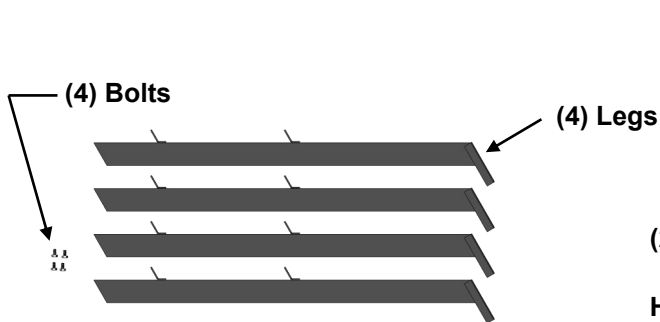
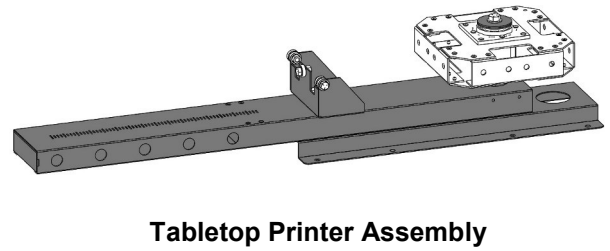
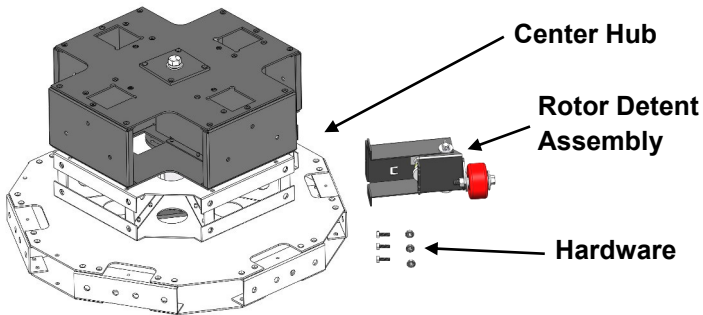

Standard Print Head

HD Print Head

V-1000 4 Station 6 Color Press

Model#: V1-46

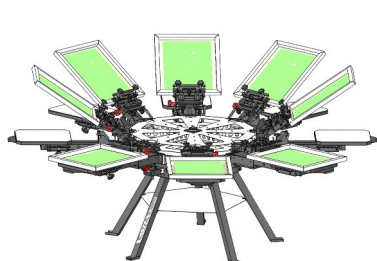
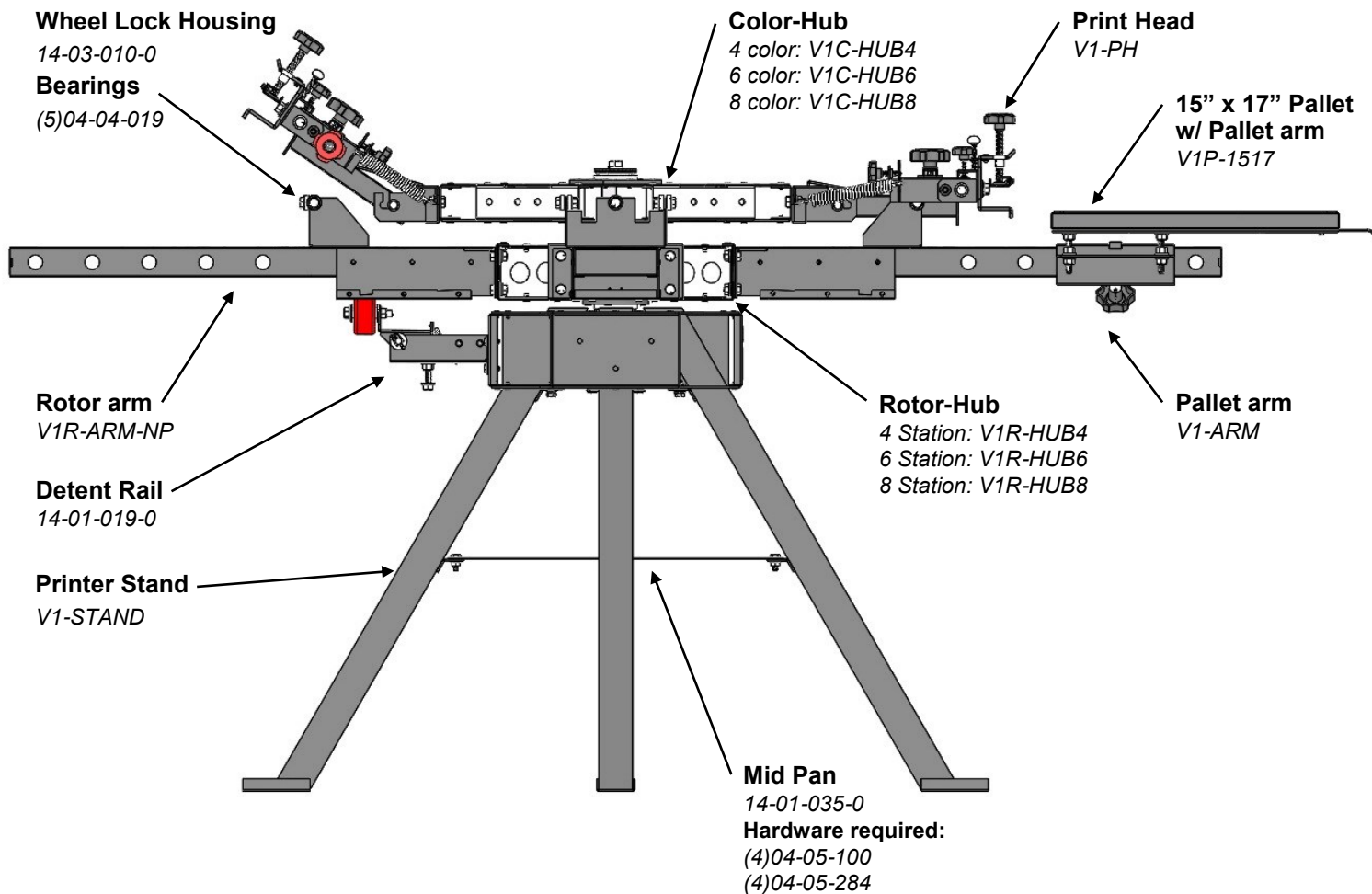

V1-88



V1-46

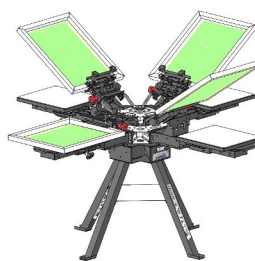

V1-44

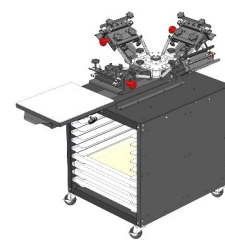

V1-T14 w/ optional Utility Cart

Component Identification / Print Head

Standard Print Head Overview:

The V-1000 Printers utilize floating print heads. When the print heads are lowered they lock into a Wheel Lock Housing. This effectively disengages the print head from the "C" hub and precisely aligns it to the pallet. The floating print head will only function properly if screens are set with **off contact** over pallets.

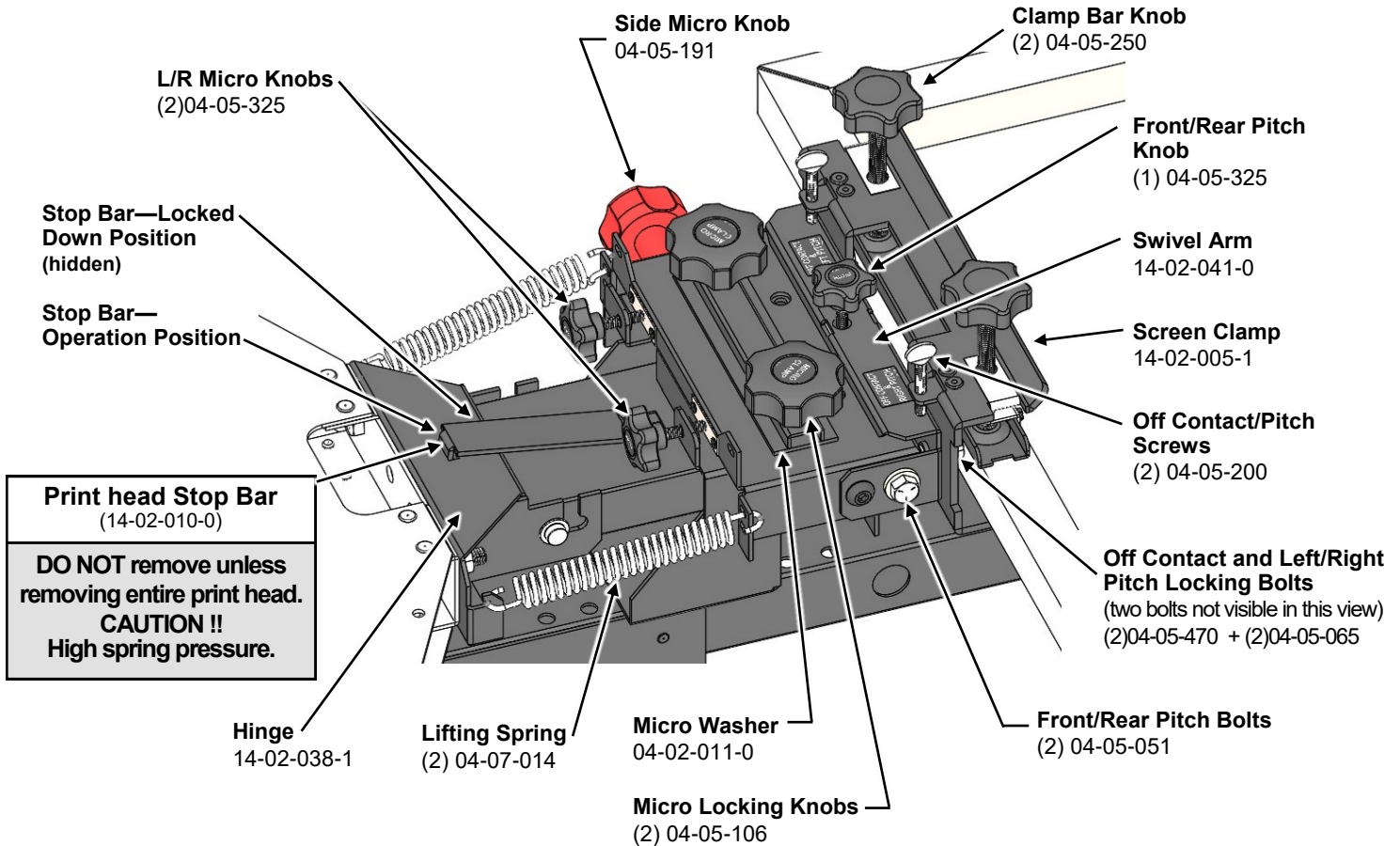

HD Print Head Upgrade not shown

Uses hinge p/n 14-02-044-1, 2 more Lift Springs, and a Kickstand Assembly. All leveling and Micro functions are the same.

- **Front/Rear Pitch Knob:** Loosen the Front/Rear Pitch Bolts, turn knob to pitch the screen up and down.
- **Stop Bar:** DO NOT remove unless removing entire print head. There are two positions; Operation, stops the Print Heads in the up position, and Locked Down, holds the screen in the down position.
- **Lifting Springs:** The coil springs hold the Print Head up, and pull tension for the micro adjustments. There are multiple positions for different screen and accessory weights.
- **Micro Adjustment Locking Knobs:** Loosen 1/4 turn before making micro adjustments. Retighten when complete.
- **Side Micro Knob:** (red) Controls side to side micro adjustment.
- **Left & Right Micro Knobs:** Rotates the screen several degrees in either direction and moves screen front to back.
- **Off Contact Locking Bolts:** Must be loosened slightly to make Off Contact adjustments.
- **Off Contact Adjusting Screws:** Used to level and set the distance between the screen and pallet.

Note: For Micro Registration, loosen the Micro Adjustment Locking Knobs slightly before making screen adjustments. Check that locking knobs are tight before setting off contact.

Assembly

Tabletop models skip to page 12.

V1-88 skip to page 8.

1

- 1) Place box marked Center Hub Assembly in an open area of your shop floor. Remove top of box. Center Hub assembly can remain in the box while installing legs and optional service pan.

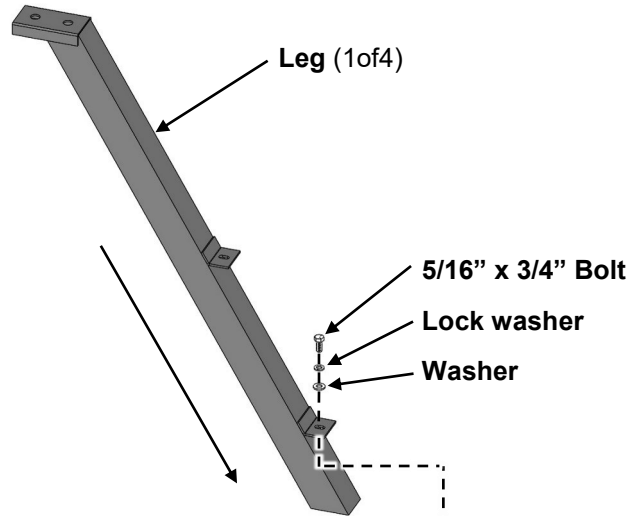

- 2) Remove 5/16 x 3/4 lg. bolt, washer, and lock washer from the bottom of the Center Hub Assembly. Insert a leg through both rectangular openings in the upper and lower base plates of the base hub until the angled mounting bracket is laying flat against the base plate. The openings are intentionally tight, use hammer if needed. Reinstall bolt, washer, and lock washer through the angled mounting bracket. Tighten bolt securely with 1/2" wrench.

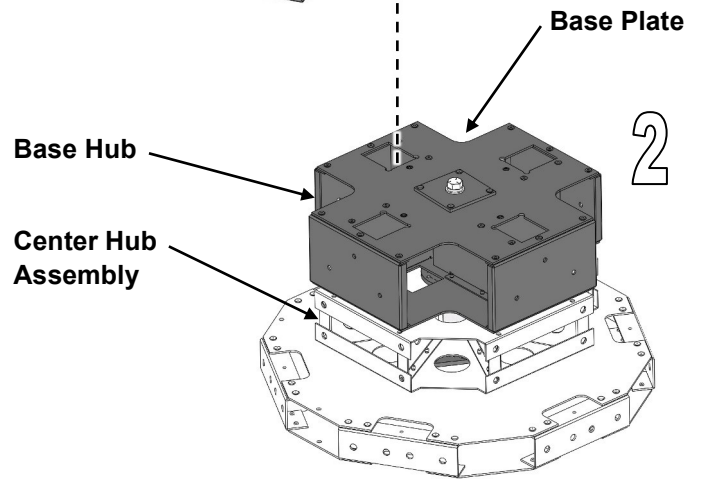

- 3) Install three remaining legs like in step 2. Make sure all bolts are tight. Carefully turn machine over onto legs.

- 4) Install Mid-Pan. Mid-Pan rotates into place and is installed with (4) 5/16 x 3/4" bolts and Serrated Nuts.

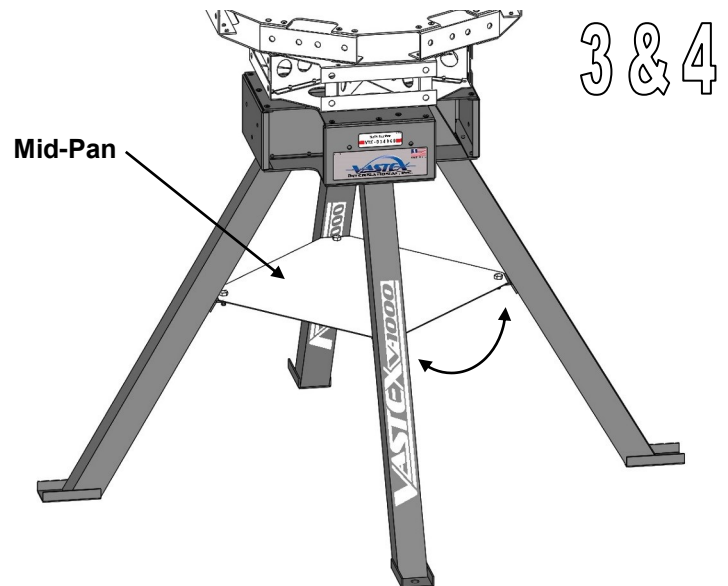

Assembly cont'd

Note:

The V1-88 stand comes partially assembled, with one leg removed for crating.

- 5) Remove the Hardware from the Mid-Pan at the position of the missing leg.

Remove Hardware

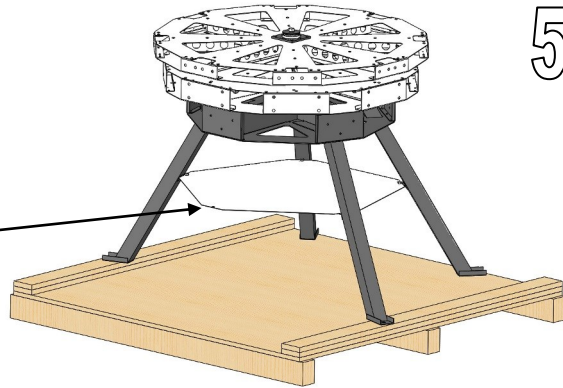

- 6) Slide the fifth leg into the rectangular opening of the Center Hub and fasten with the 5/16 x 3/4" bolt, washer, and lock washer. Once installed reinstall 5/16 x 3/4 bolt and serrated nut to attach the Mid-Pan to the leg.

Note: You may need to tilt leg in order to slide it into the bottom of the Center Hub.

- 7) Slide stand off of the pallet, (unless installing wheels.) It is handy to slide one leg off the skid at a time to install the Drop Down wheels.

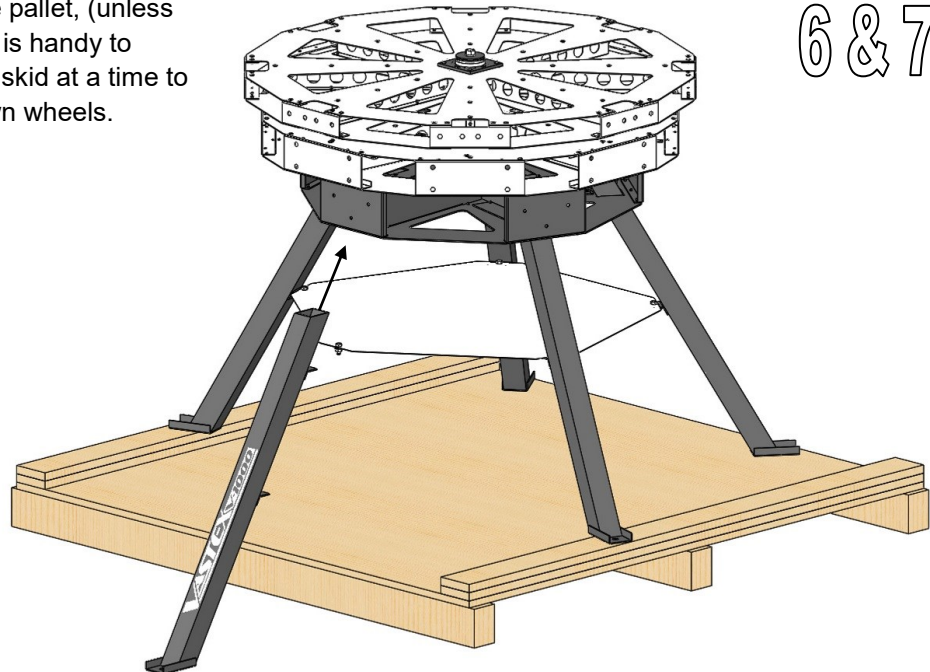

V-1000 Drop Down Wheel Set Installation (optional)

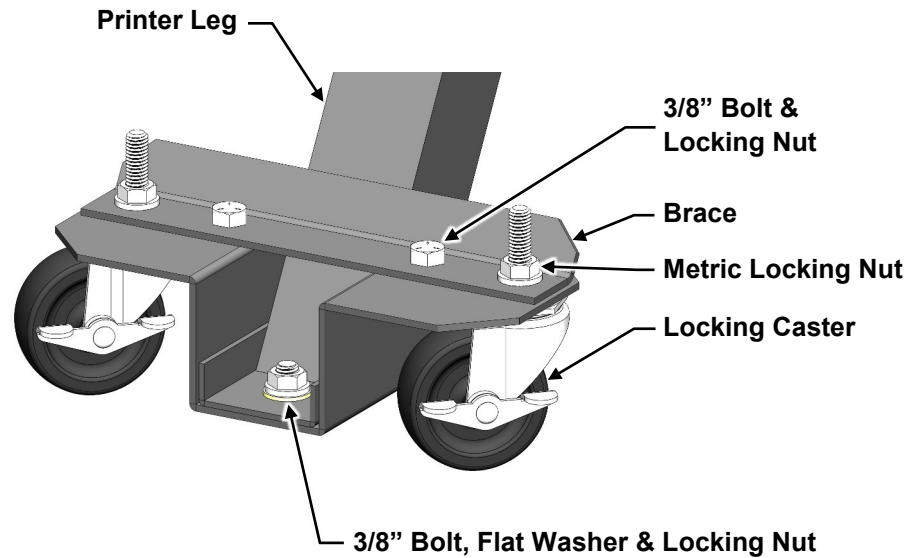

Tools Required:

9/16" Wrench
15mm Wrench

Wheel Set Installation:

1. Bolt the brace to the offset plate using (2) 3/8" bolts and locking nuts.
2. Attach the casters to the offset plate and brace using metric locking nuts.
3. Carefully lift the press and slide the wheel set assemblies under each leg.
4. Secure the wheel set assemblies to each leg. Place a flat washer on the bolt, install from the bottom, secure with a 3/8" locking nut from the top.



Drop Down Wheel Set Installed

Assembly cont'd

- 8) Install the Rotor Detent Assembly using three 1/4" x 3/4" bolts and serrated nuts. Tighten well using a 7/16" wrench. Install the assembly on any one of the four sides of the Base Hub. Once you have Rotor Arms installed, adjust the detent roller by loosening the lock nut with a 9/16" wrench. Turn the screw out to increase or in to decrease the holding pressure. Retighten locking nut after adjusting. Two springs are supplied, in most cases only one needs to be installed.

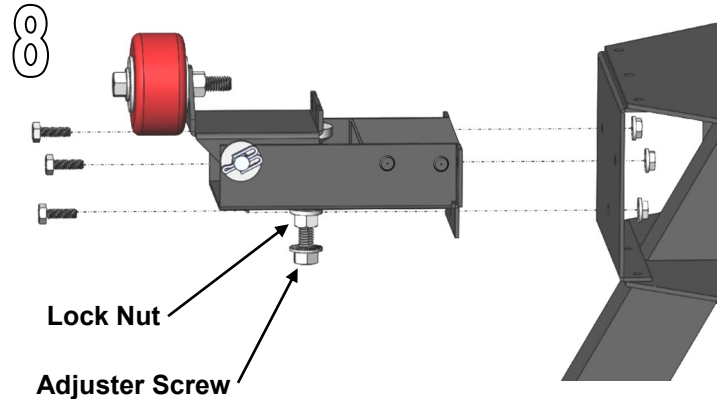

- 9) Install the Wheel Lock Housings onto the rotor arms. There are three mounting locations (shown on right). Select the correct set of holes for your printer. (V1-88, V1-66, V1-46, All machines 4 colors or less) Attach wheel lock housings to rotors arm with four 3/8" x 3/4" bolts and square nuts; 9/16 socket and ratchet required. The square nuts are installed under the Rotor Arm and will not spin while tightening the bolt.

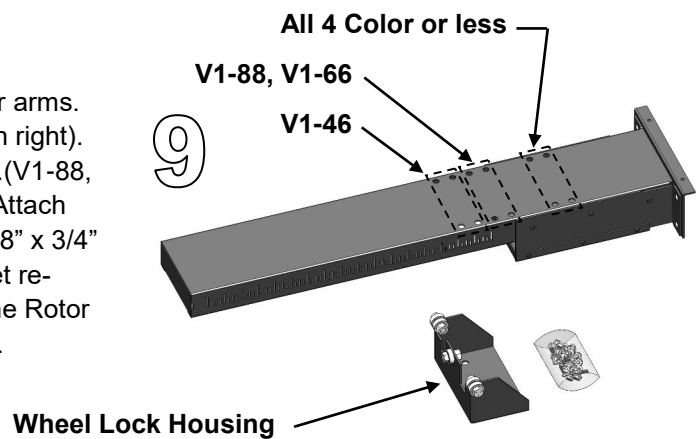

Wheel lock housing pictured may differ from included part. Mounting and function remain the same.

- 10) The Rotor Arms have Hook Pins to allow hanging the arm on while inserting hardware. When installing each arm, simply hook it onto the Rotor Hub, then install four 3/8 x 1" lg. bolts, and serrated locknuts. Two 9/16 wrenches are required. Continue with installation of remaining Rotor Arms. go back and check each bolt, tightening them securely.

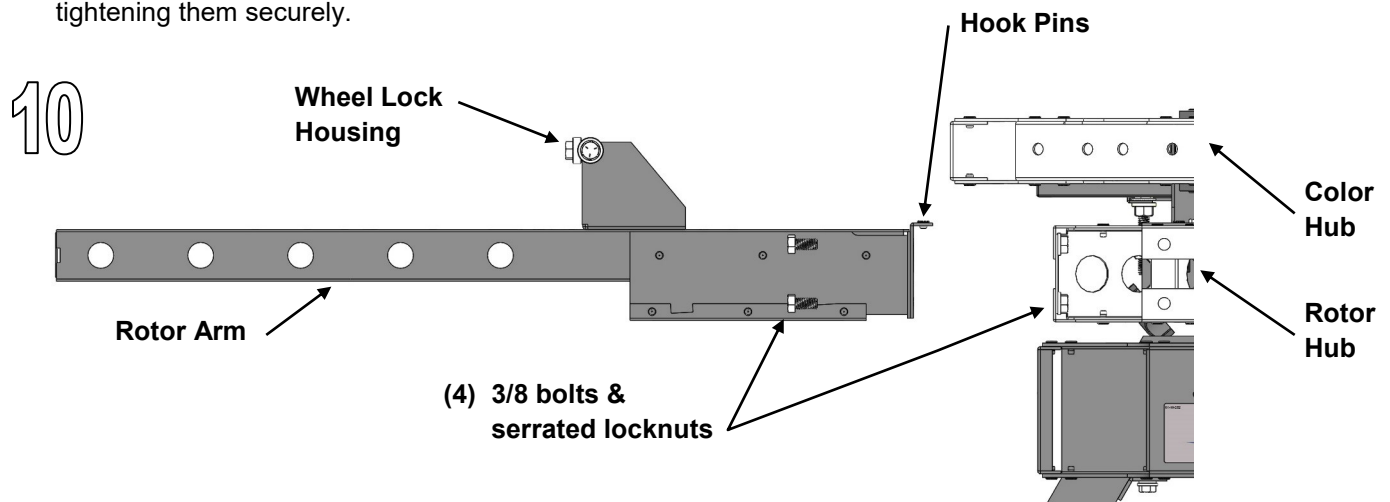

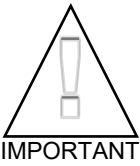

Wheel Lock Housing Level Check

The following instructions will help determine if shimming the Wheel Lock Housings (WLH) is needed. A slight variation in level between housings is acceptable, but the closer the better. See FIG A for allowable limits.

Checking Level Between Wheel Lock Housings (WLH)

- 1) Rotate the Rotor Arm until it is engaged in the detent roller.
- 2) Select one rotor arm to begin checking level. Position a level across the top of the side bearings. Note the bubble location within the Level Site Window.
- 3) Rotate the next Rotor Arm to you in the same position. Do not walk to next arm, stay in one position for all readings.
- 4) If all the readings are within limits shown below, no shimming is needed.
- 5) If the bubble is beyond limits shown on any one or all WLH's identify that one with a piece of tape.

See below for shimming procedure.

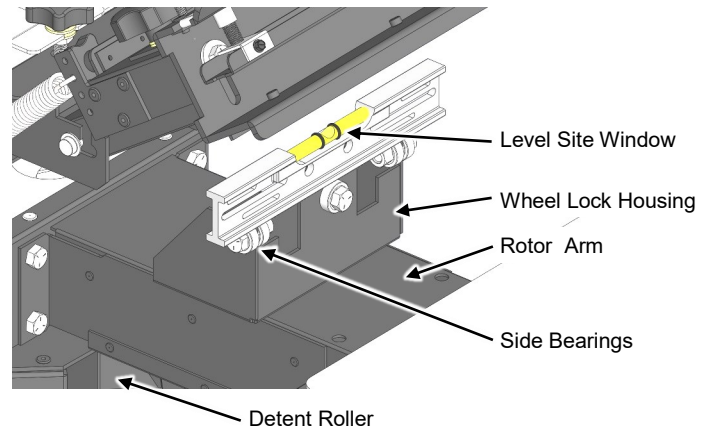

Site Window Maximum Allowable Limits Between Arms (Maximum allowable difference between all Wheel Lock Housings)

Half bubble max between arms

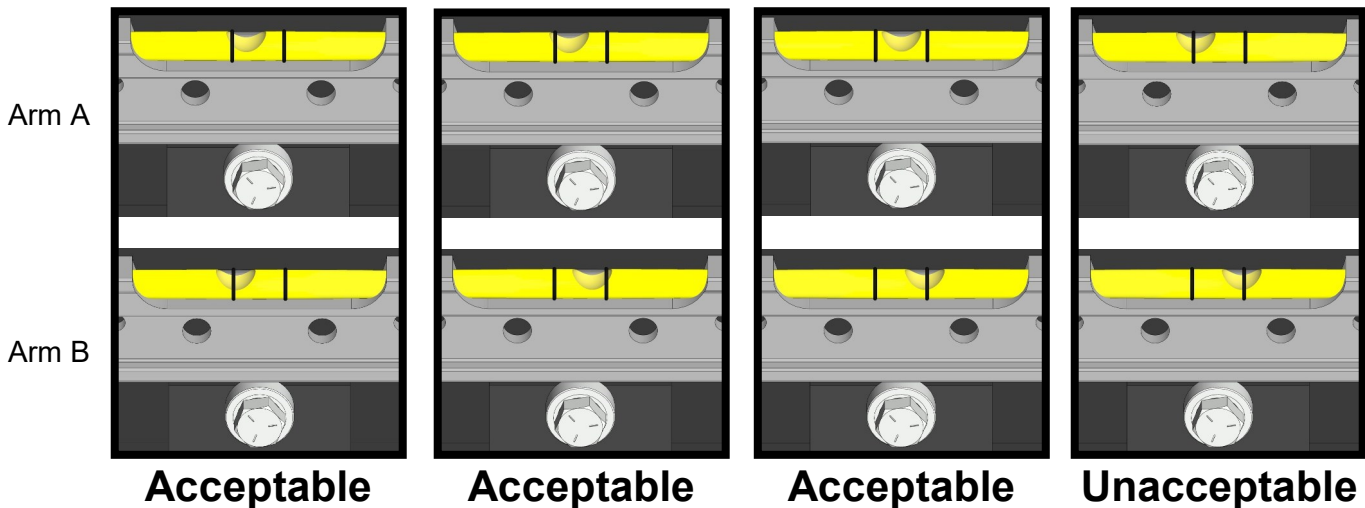

Shimming a Wheel Lock Housing

- 1) Identify the most level housing, leave that one tight.
- 2) To shim a WLH, use a 9/16" wrench and loosen all four mounting screws.
- 3) Slide a shim between the Rotor Arm and the Wheel Lock Housing on the low side.
- 4) Gently push the housing toward the center of the press while retighten the four mounting screws.
- 5) Recheck all Wheel Lock Housings to ensure they are all within approx. 1/2 of bubble level.

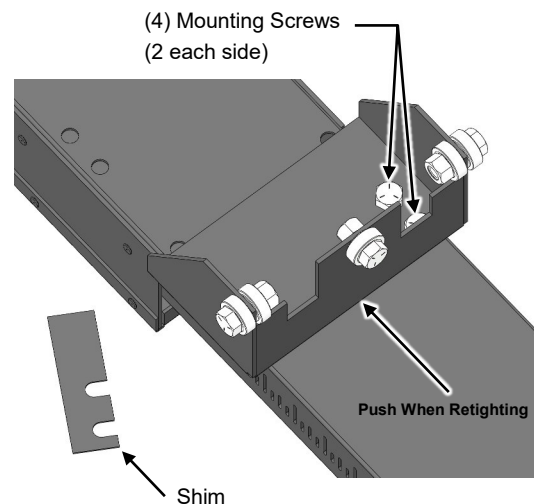

Assembly cont'd

11) Install the hinge on to the "C" Hub by using (2) 3/8-16 x 1" carriage bolts, washers, and serrated nuts as shown. Use the two outside holes to mount to Hinge. Install all Hinges on to the press at this time.

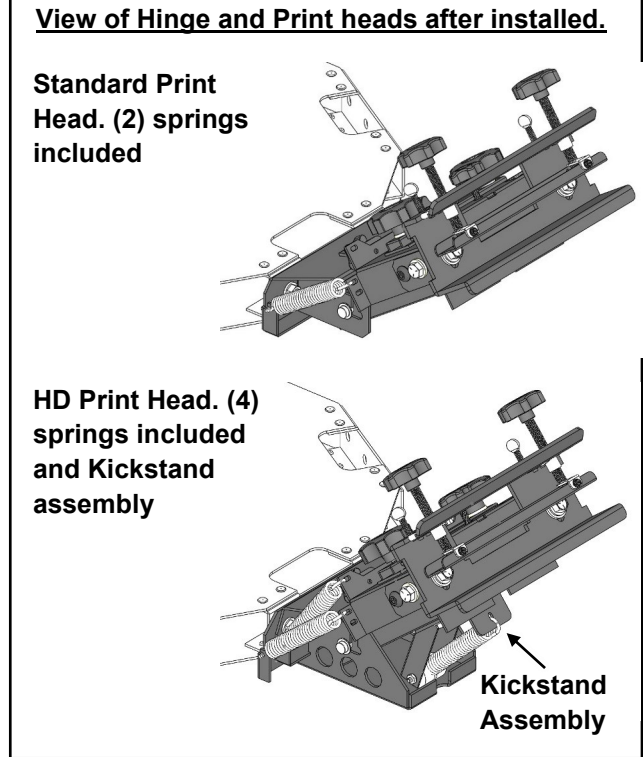
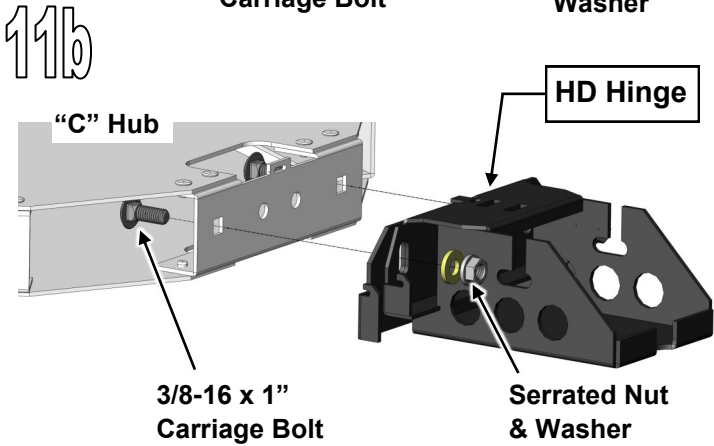
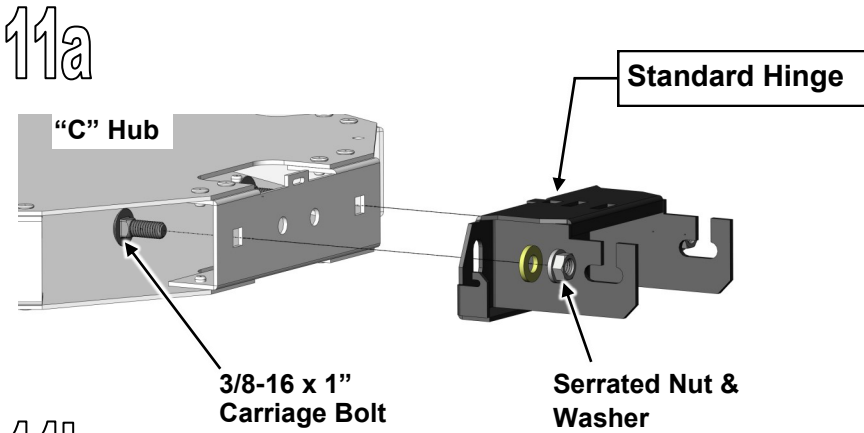

Print Head Install. Standard and HD are the same, Standard shown.

12) Insert the print head in to the hinge as shown in Figure 12, Standard Print Head shown. Apply grease to the pin and slots as indicated. Lower head onto bearings after slid into place.

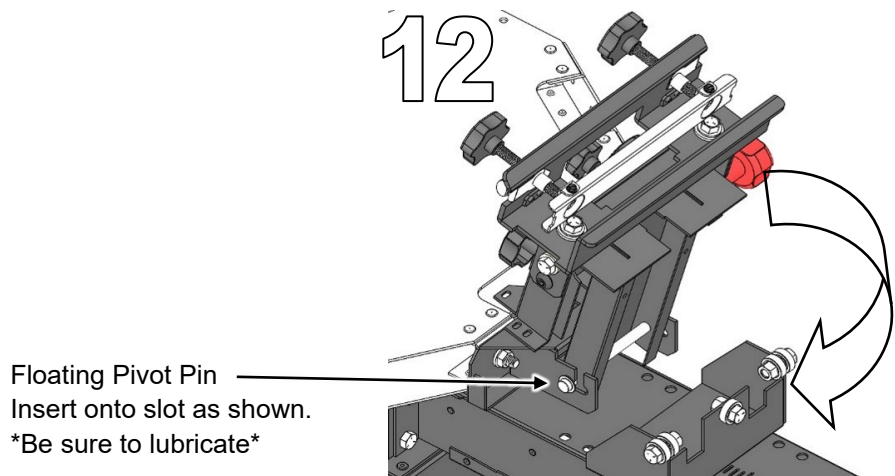

Caution must be taken when installing springs, high force present.

See below spring locations, Regular and HD Print Heads. Installation instructions on next page.

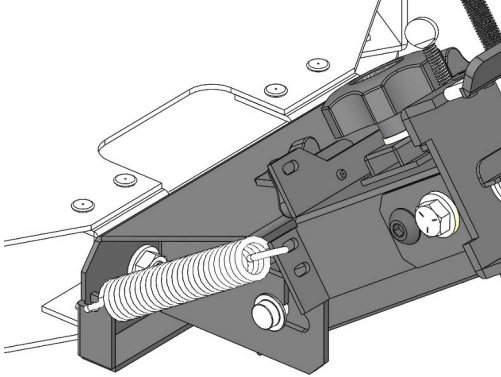

Standard Print Head Using a screen up to 3 lbs (1.4kg)

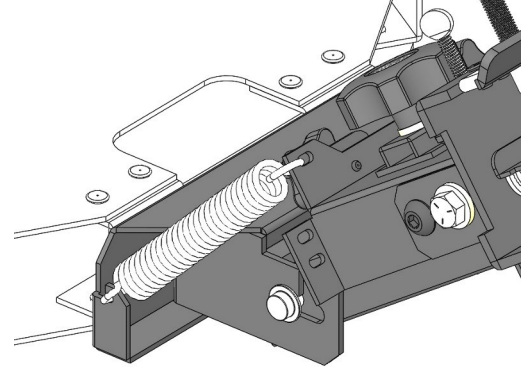

Standard Print Head Using a screen up to 6 lbs (2.8kg)

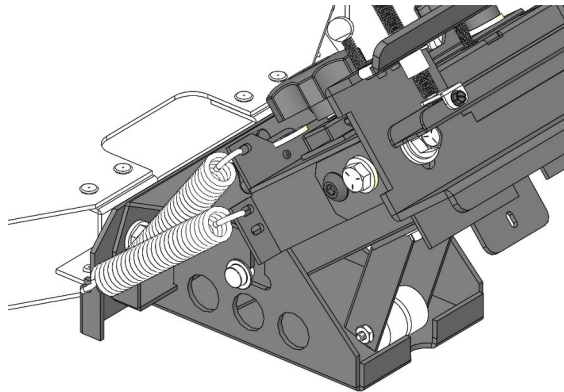

HD Print Head. For screens or attachments up to 20 lbs (9kg).

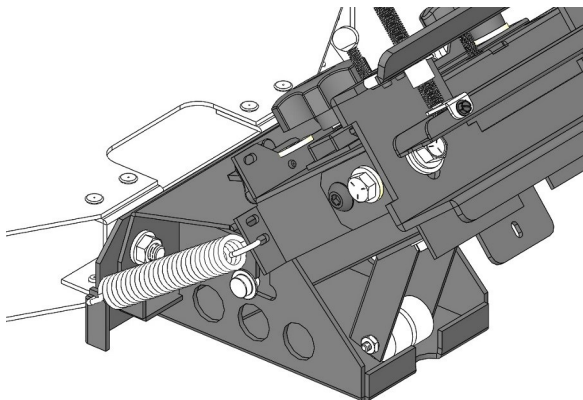

HD Print Head Using a screen up to 3 lbs (1.4kg)

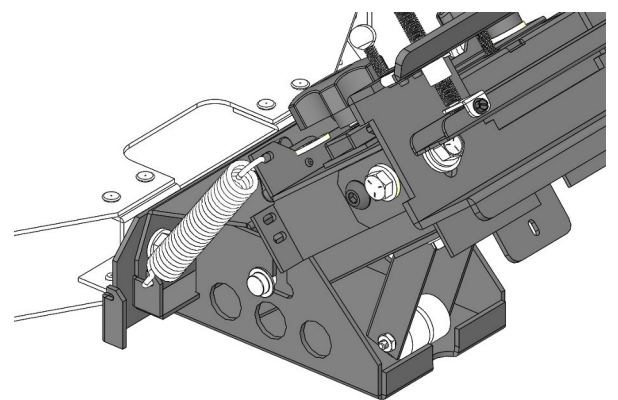

HD Print Head Using a screen up to 6 lbs (2.8kg)

Assembly cont'd

13) Spring installation on Standard Print Head.

There is (1) spring each side. See previous page for best locations. Always hook springs from the outside in. Tilt the entire assembly back and install top (moving) side first, then install the bottom of spring into the hook on the hinge

Be sure the springs are seated well before moving on.

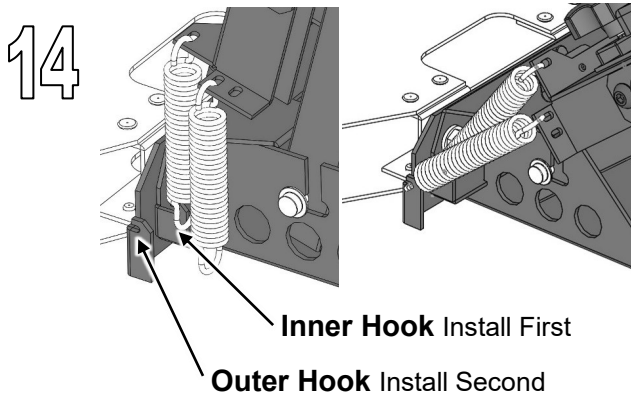
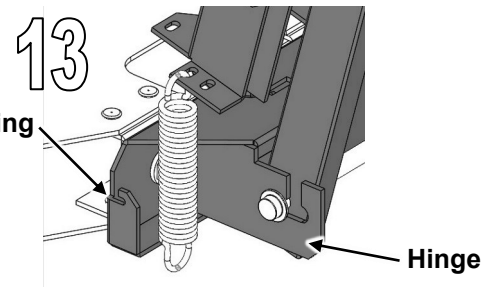

Step 15 for HD Print Head Only

14) Always hook springs from the outside in. Tilt the entire assembly back and install the top spring (on both sides) into the inner hook on Hinge. Then install the bottom springs into the outer hook.

Be sure all 4 springs are seated in their slots holes before moving on. This may require a second person.

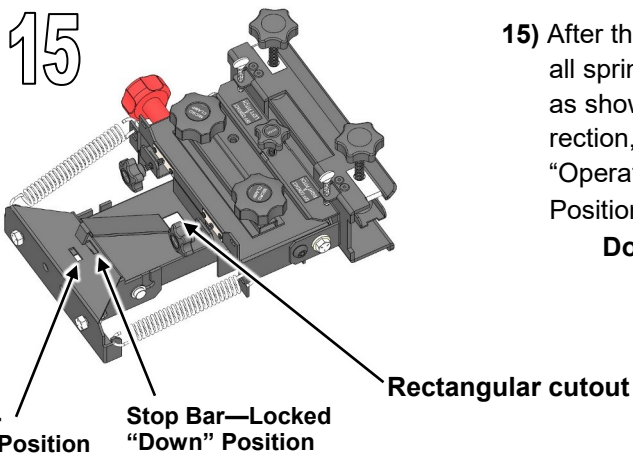

15) After the Springs are installed, lower the print head while insuring all springs stay seated correctly. Install the Stop Bar into the slots as shown on the left. The Stop Bar can only be installed in one direction, but has two positions. When the Stop Bar is in the "Operation

Position" it is safe to raise and lower the print head.

Do Not allow the print head to swing into its raised position unrestrained!

Install remaining print heads at this time.

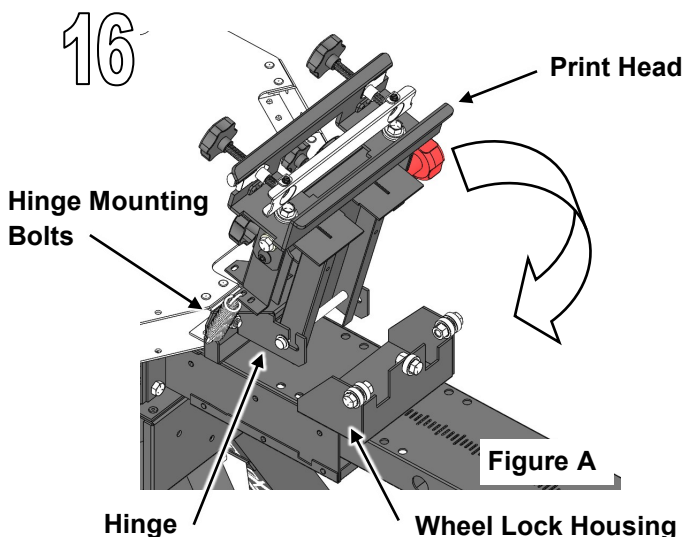

16) Very Important Step !!

Setting Hinge level and position.

- 1) Loosen the (2) Hinge Mounting Bolts by 1/2 turn only.
- 2) Push the Print Head down several times to engage it with lock bearings. This is to "SET" the hinge into its natural position.
- 3) Lower print head and move stop bar to locked down position.
- 4) Tighten the (2) Hinge Mounting Bolts firmly.
- 5) Return the Stop Bar to the Operation position and raise print head.
- 6) **Repeat** this step with each Print Head on to the SAME Wheel Lock Housing

Assembly cont'd

18) The Neck Guide attaches to the end of the pallet and aids in the loading of shirts onto pallet. Place pallet, rubber side down on a flat protected surface. If installing the neck guide, slide it into the end of the pallet and secure with two sheet metal screws using a 1/4" wrench. Be careful not to over tighten or cross thread the screws! **Note:** neck guide is needed if using Vastex Jacket Quick Stretch.

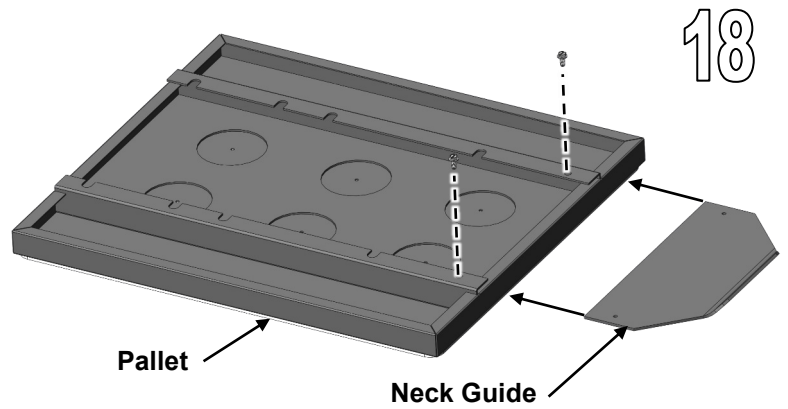

19) Place one washer onto each 3/8 x 3"lg. flanged hex bolt. Thread nuts to within 1/4" of bolt head. Slide bolts into open ended slots on bottom of pallet. Use the slots closest to the end of the pallet and 5-1/2" to next bolt. The washer must be on the nut side of slot, to allow the flange of the bolt to grip the metal. Tighten the nuts using two 9/16" open end wrenches, making certain bolts are all the way in their slots. Thread a nut approximately half way onto each bolt as shown on the right.

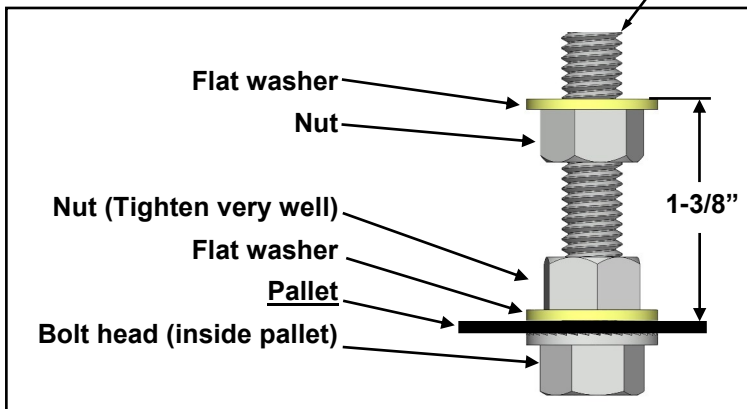
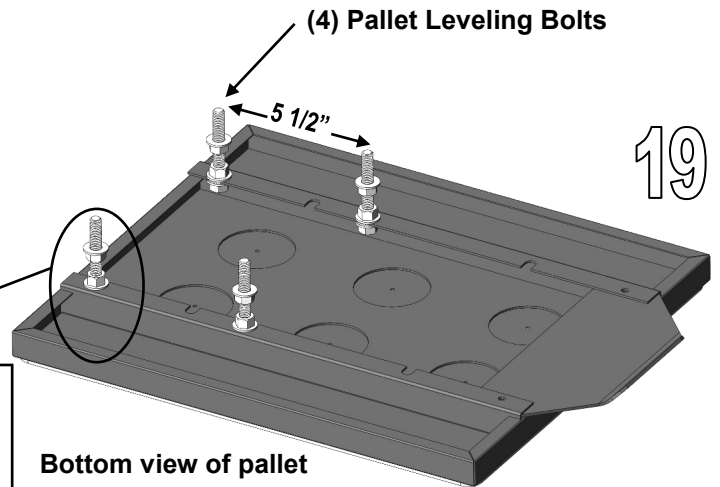

20) Assemble the pallet arm onto the pallet using 3/8-16 Nuts and Flat washers, as shown. Leave these nuts loose until you are ready to level the pallets. (Pg14)

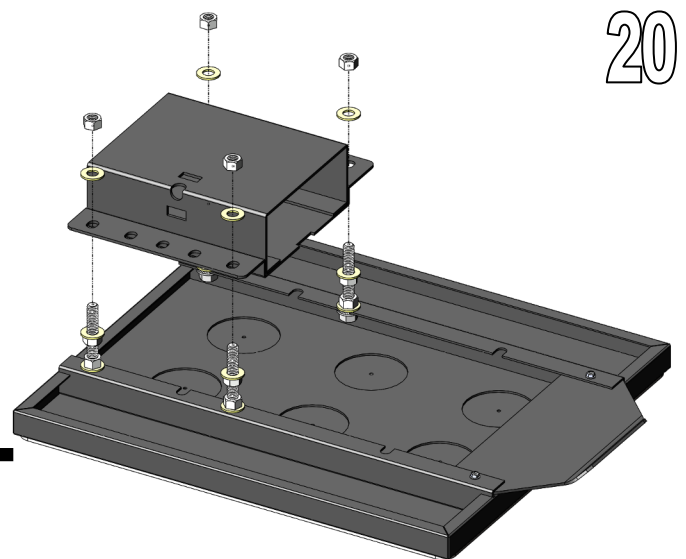
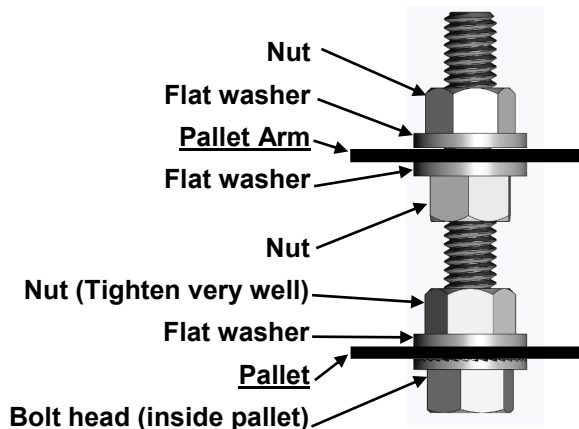

Assembly cont'd

- 21) Install Corner Tab and Corner Nut as shown on right. Then, install Clip, Hairpin to secure Corner Tab in place.

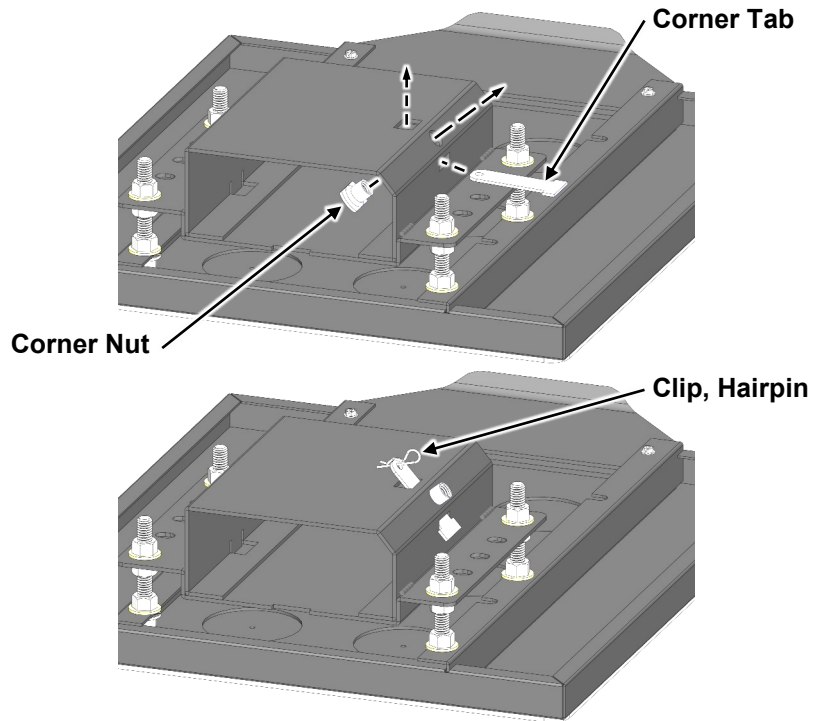

- 22) Install Pallet Knob. Leave loose. (Make sure knob is lubricated)

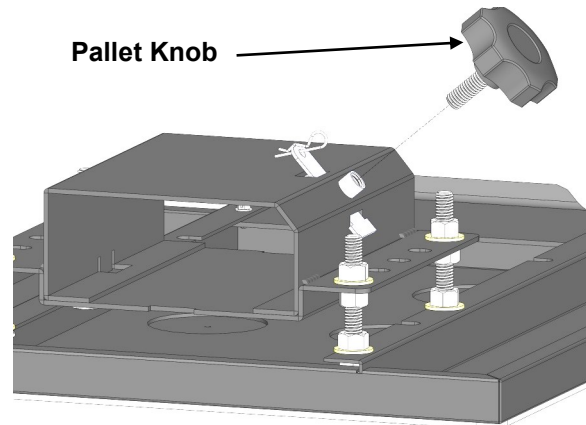

- 23) Install Pallet and Arm onto Rotor Arm. Repeat these steps for each Pallet needing to be assembled.

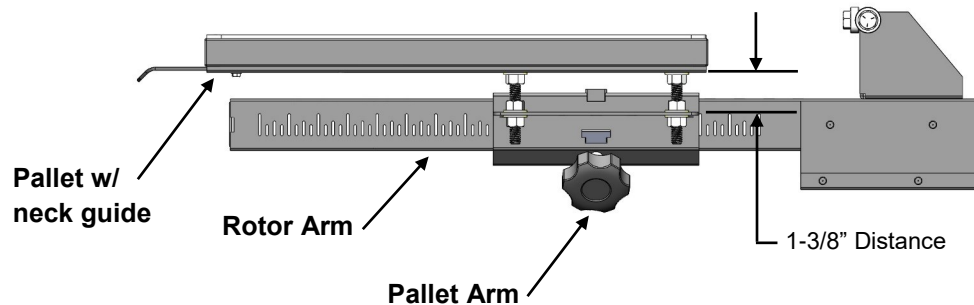

Continue to Pallet Leveling and Head leveling once each pallet is assembled and installed onto press.

Pallet Leveling

Note: Level only one pallet with the following procedure and mark this pallet as #1. Then level all print heads to this pallet. See Print Head Leveling for instructions.

- 1) First, tighten the pallet arm locking knob. Take a reading from a level placed on the bottom of the pallet arm.

Pallet Adjusting Nuts

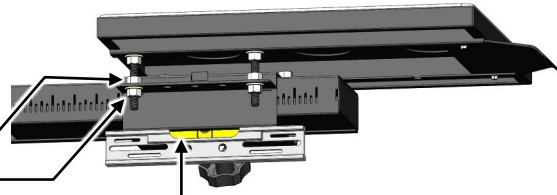

Make these readings match

- 2) Move the level to the top of the pallet towards one side. Adjust the pallet to match the reading taken from pallet arm. Move the level to the opposite side and adjust to the pallet arm reading. Recheck both sides after making adjustments.

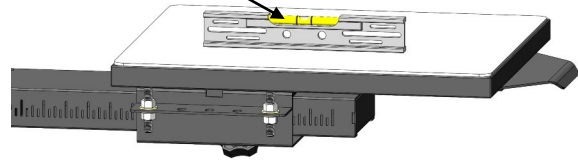

Important: Before moving to Step 3 the Wheel Lock Housing must be leveled. See Page 11.

- 3) Place the level across the Wheel Lock Housing and take a reading.

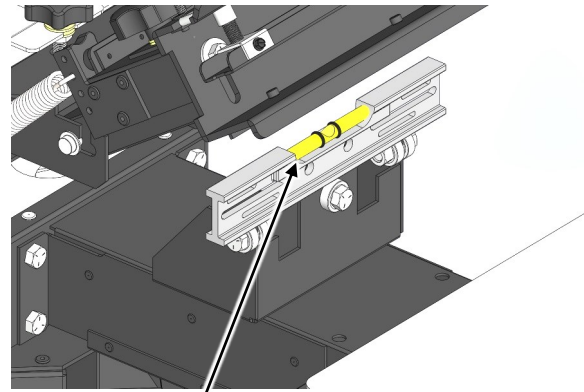

Make these readings match

- 4) Move the level to the top of the pallet towards one side. Adjust the pallet to match the reading taken from pallet arm. Move level to the opposite side and adjust to the pallet arm reading. Recheck both sides after making adjustments.

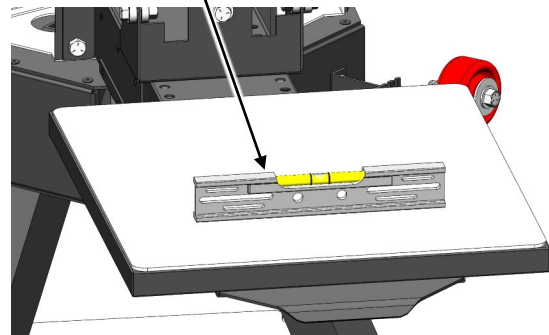

- 5) Recheck level readings in all directions and make any necessary adjustments. **Important**, before tightening all the bolts make sure that the (4) Pallet Leveling Bolts are located in the center of slots in the Pallet Arm.

Pallet Leveling Bolts

Centered in Slot

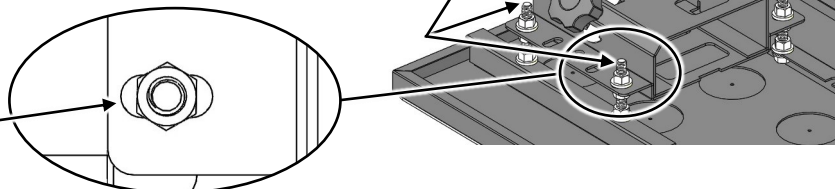

Print Head Leveling

Please review Print Head overview to better understand all adjustments.

- 1) Clamp a screen into the Print Head over Pallet #1. Lower the screen onto the pallet and adjust the off contact to be 3/8" (10mm) off the pallet. We know this is too high, we will lower it later in the setup.

NOTE: Level is not important here, just make sure the screen dose not touch the pallet.

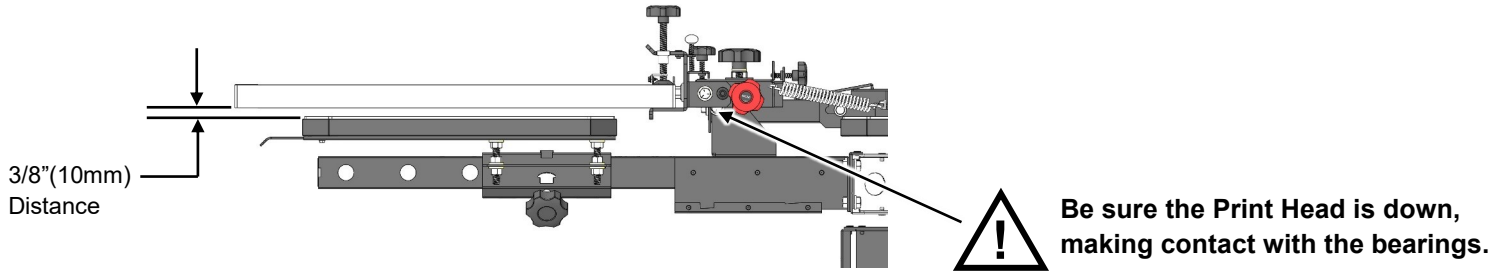

- 2) **Adjust front to back level.** Loosen the Front/Rear Pitch Bolts, located on the each side of the Print Head, by 1/2 turn. Adjust the screen to be parallel to the pallet from front to back by rotating the Front/Rear Pitch Knob either clockwise or counter-clockwise. Tighten the side bolts back up after leveling.

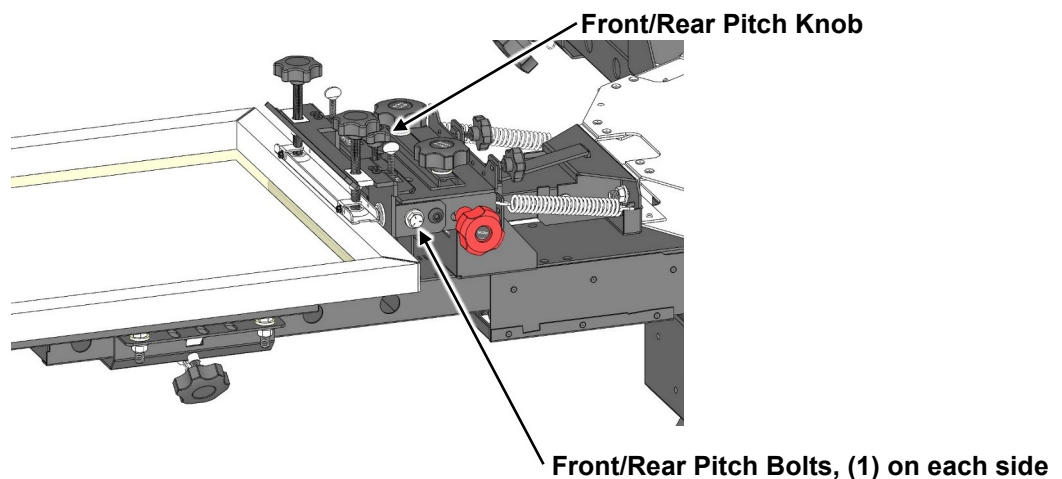

- 3) **Adjust the side to side level.** Loosen the Off Contact / Left/Right Pitch Locking Bolts, located on the front of the Screen Clamp, by 1/2 turn. Make sure the screen is not touching the pallet. Turn the Off Contact/Pitch Screws, one at a time, to set the left to right pitch of the screen parallel with the pallet. To lower the screen, you will have to apply down pressure.

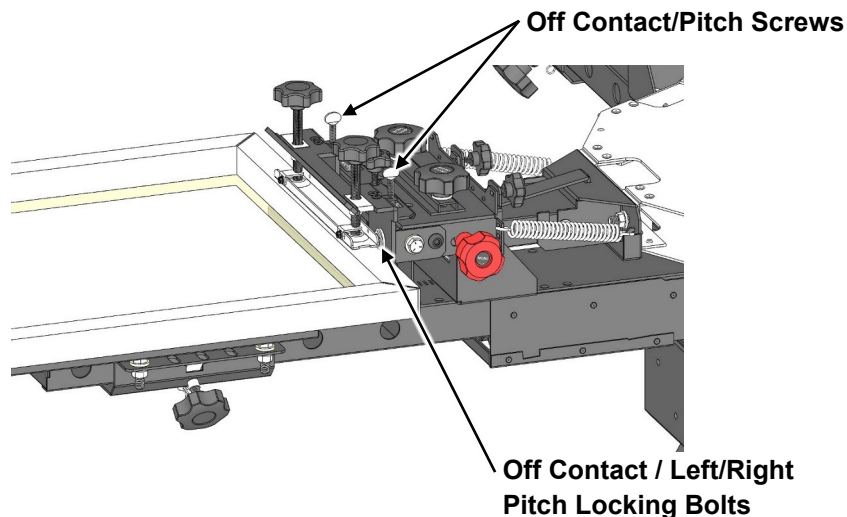

Print Head Leveling

- 4) Tighten the Off Contact and Left/Right Pitch Locking Bolts and check that the screen is parallel in both directions still. It may be needed to do both adjustments again once all bolts are tight.
- 5) With your screen now level front to back and left to right, loosen the Off Contact / Left/Right Pitch Locking Bolts again by 1/2 turn. Use the Off Contact/Pitch Screws to lower your screen to have an off contact of 1/8"(3mm) off the pallet. Tighten the bolts back up after setting the off contact.

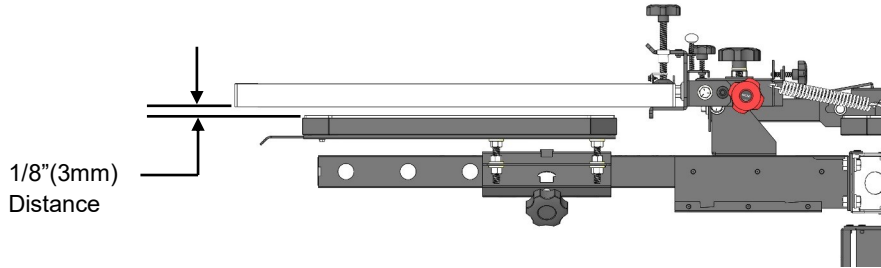

For repeatable registration the screen must have off contact!

At this point one pallet has been leveled to its rotor arm and print head #1. Now we want to adjust the remaining pallets to the leveled print head while centering the pallets over the rotor arms.

- 6) With Print Head #1 lowered over Pallet #1, loosen the Clamp Bar Knob and slide the screen you just leveled so that the screen edge is aligned with the pallet edge. This will be used to make all pallets the same side to side. Retighten the Clamp Bar Knobs.

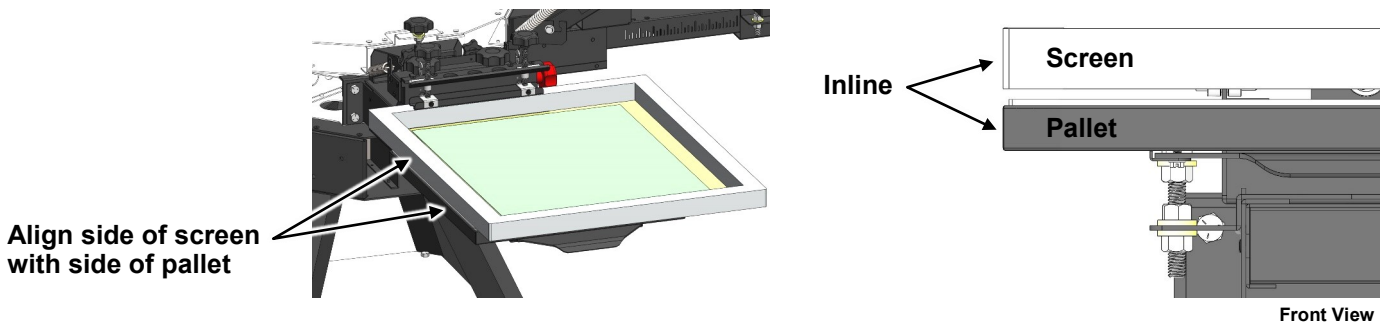

- 7) Take that Screen and locate it over the next pallet. Lower the screen onto the Wheel Lock Housing. **DO NOT MAKE ANY ADJUSTMENTS TO THE SCREEN** and use this screen to level the pallet to it by adjusting the Pallet Leveling Bolts. Before tightening the nuts, be sure to align the side of the pallet to the side of the screen. Repeat this step for the remaining pallets. Each pallet must have 1/8"(3mm) of off contact from the screen.
- 8) After all your pallets are leveled and side adjusted to that first screen, you can now level the remaining heads to any of the pallets by following Steps 1 through 5.

Your Vastex Printer is now ready for printing shirts. Scan the QR code on the front page for resources and help.

Lubrication / Maintenance

****V-1000 Press comes with a small bottle of oil, and a tube of grease to maintain your press properly. Please follow all lubrication instructions to prevent premature wear ****

Lubrication

- Main center column bearings can be lubricated with a light oil. Apply oil at the edge of the bearing plate, located at the top center of the printer. This plate holds the top bearing down, which pre-loads all the center bearings. Oil will drip down and lubricate all four bearings. Once per month (under normal daily use) approximately 1/2 oz. of light machine oil can be squirted along the side of the bearing. Apply 1/4 oz. and then spin both hubs. Apply the second half and then spin both hubs again. In time oil may be detected seeping out from beneath the lowest bearing and above the stand center box. Clean off as needed.
- Apply a dab of grease to the following locations:
 - Both sides of the print head pivot pin.
 - All adjustment bolts and knob threads. This will ensure ease of movement and prolong their life.
 - Mounting holes for the lifting springs.

Replacement Lubricants can be ordered at Vastex International Inc.

P/N 04-05-300 Oil 4 oz.

04-05-301 Grease 1.5 oz.

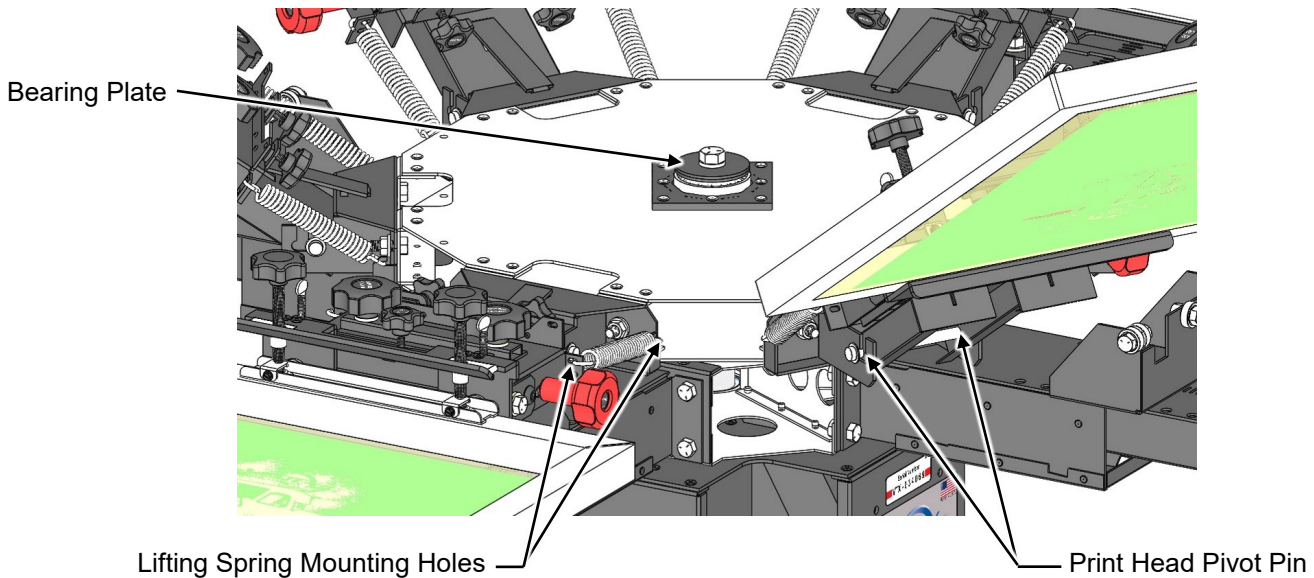

Cleaning

- Clean your machine on a daily basis or between each job. Particularly removing lint around moving points and adjustment areas. A clean machine is more likely to be maintained properly than a messy one. Any solvents can be used on the pallet tops for cleaning. The painted surfaces should be cleaned with detergent, like a glass or multi-surface cleaner, to remove lint and dust. Mineral spirits can be used to remove spilled inks.

Inspection

- Inspect your machine on a monthly basis for untimely wear or any other signs of problems. This can be done while lubricating and should take no more than a few minutes. Finding a problem early can reduce the cost of downtime and repair.